

# IVHW System Concept and Issues relevant for Standardization

## DEUFRAKO Project Consortium

(ISIS, RENAULT, DAIMLERCHRYSLER, PSA PEUGEOT CITROËN,  
COFIROUTE, ESTAR, BOSCH, INRETS, BAST)

- Preliminary final -

Compiled by Ina Becker  
DaimlerChrysler (WP 3.3)  
Sept. 12<sup>th</sup>, 2002  
Updated June 20<sup>th</sup>, 2003

Contact:  
Benoît Maisseu, Renault  
Phone: +33 1 34 95 76 45  
Email: [benoit.maisseu@renault.com](mailto:benoit.maisseu@renault.com)

## Abstract

On European roads, a multitude of accidents occur due to of poor visibility conditions. Especially in cases of fog the number of severe traffic accidents is highly above average.

The optical warning devices of the vehicles (lights, rear fog-lights, hazard flashers, warning triangle) are obviously not sufficient for effectively alerting other vehicles approaching a potentially hazardous situation, i.e. the end of a queue on a motorway.

Already two decades ago it was found in the PROMETHEUS research programme, that direct vehicle-to-vehicle-communications holds a big potential to improve traffic safety under such traffic conditions by early informing the driver on dangerous situation ahead.

However, to implement a warning system that works without false alarms requires to determine the distance of a vehicle relative to the location of the dangerous situation. Only recently, with the fast increasing number of vehicles on European roads equipped with GPS or navigation systems this enabling technology basis in the vehicles is emerging.

Nevertheless, the problem of materialising an adequate vehicle-vehicle communication system at marginal costs needs still to be resolved.

This challenge has been in the focus of a the Inter-Vehicle Hazard Warning (IVHW) research project (2001-2002) within the DEUFRAKO (German-French-Cooperation) framework aiming at developing a system concept for a IVHW system giving precedence to European highway traffic.

The warning system concept finally delivered by the project can be understood as an expansion of the optical signalling range of the hazard flashers by a radio message emitted simultaneously. To accommodate the data communications between the vehicles an unlicensed ISM frequency band at 869 MHz that is available throughout Europe was found to be best suited.

Clearly, in order to make Inter-Vehicle Hazard Warning effective in the European road traffic a significant number of vehicles need to be equipped with the respective device. Therefore, a key prerequisite for further progress is an agreement of European car manufacturers on the functionality of those IVHW system elements which are crucial for the interoperability of the IVHW devices of all vehicles independently of the respective brand.

In this paper the IVHW system description and draft specifications for the IVHW message content as well as for the characteristics of the radio communication systems have been compiled.

It is the objective of this document to share the idea of IVHW with all members of EUCAR, to invite their comments on the system concept and to achieve a consensus on crucial specifications. Having accomplished the joint support of the European Car Manufacturers on these topics official standardisation could be envisaged as the next step.



## Table of Contents

Abstract.....	ii
1. System concept .....	1
1.1 Accident .....	2
1.2 Generic warning .....	2
1.3 Stopped vehicle .....	2
1.4 Warnings emitted by infrastructure beacons .....	3
1.4.1 Accident.....	4
1.4.2 Generic warning .....	4
1.4.3 Stopped vehicle .....	4
1.4.4 Roadworks.....	4
1.4.5 Traffic congestion .....	4
1.4.6 Very slippery road.....	4
1.4.7 Heavily reduced visibility .....	5
1.4.8 Vehicle on wrong carriageway.....	5
2. Issues for standardization .....	6
2.1 Message structure and size .....	6
2.1.1 Overview table.....	6
2.1.2 Message sections content description.....	6
2.2 Transmission techniques .....	14
2.2.1 Requirements .....	14
2.2.2 Hardware specification .....	14
2.2.3 Existing Regulations .....	15
2.2.4 Channel access .....	16
2.2.5 Message transfer.....	16
2.2.6 Error protection.....	16
2.2.7 Conclusion.....	16
2.3 Standardised icons for in-vehicle display.....	17
2.3.1 Accident.....	17
2.3.2 Generic warning .....	17
2.3.3 Stopped vehicle .....	17
2.3.4 Roadworks.....	18
2.3.5 Traffic congestion .....	18
2.3.6 Very slippery road.....	18
2.3.7 Heavily reduced visibility .....	18
2.3.8 Vehicle on wrong carriageway.....	18

3. Terms and definitions.....19  
    3.1 Abbreviations and acronyms.....19  
4. References .....20  
ANNEX A Detailed description of position encoding scheme.....21  
    A.1 Position encoding on sender side.....21  
    A.2 Position decoding on receiver side .....21  
ANNEX B Reed Solomon Coding .....23  
    B.1 Reed Solomon Parameters.....23  
    B.2 Basic Reed Solomon Encoder.....23  
ANNEX C Additional background information on position representation and resolution  
    25

## 1. System concept

The Inter Vehicle Hazard Warning message is activated simultaneously with the hazard flashers of the vehicle or in case of crash. Thus, whenever the driver considers it appropriate to activate the hazard flashers or in case of an accident, a radio message is being sent in a distance of about 1-1,5 km around the vehicle. Thanks to the transmitted information, including GPS positions of the emitter, the receiving vehicles can discriminate the relevancy of the warnings for themselves. Since the IVHW radio message cannot be released without active warning flashers, the visual identification of the emitter will as well contribute to reduce the misuse of the warning system.

Deliberate choice has been made on simple solutions wherever possible. With the evolution of in-car systems, the concept of IVHW could be improved in the future by including more automation or more use cases. The agreed objective of the DEUFRAKO project consortium is to develop within a short time period a workable, low cost "preferable OEM" solution.

The broadcasting of the warning message may only be stopped manually. The only exception is the automatic deactivation in order to avoid overloading of the data communication channel: Upon verification that the same message is sent by an up-stream vehicle, the emission can be stopped automatically. In this case, the coupled warning flashers are not deactivated

When IVHW emission is triggered by a crash sensor (eg. airbag) warning messages are automatically sent with no time limit and no possibility for deactivation except by the breakdown mechanic. A more sophisticated strategy could be investigated further on if this solution is not easy to implement.

For reasons of privacy protection the IVHW message does not contain any data that allows the automatic identification of the sender vehicle. In order to enable the discrimination of the sending vehicles a random vehicle-ID will be transmitted which is changed whenever the vehicle is started

The message that is sent includes several GPS positions that allow the receiving vehicles to characterize the situation and its relevance. The evaluation of the warning received with respect to its relevance for the receiving vehicle is entirely done on the receiver side to minimize associated liability issues.

Concerning the communication channel, investigations have led to identification of a candidate frequency band: 869.4 - 869.65 MHz. The basic conditions for the use of this frequency band are defined in the ERC Recommendation 70-03, published by the European Conference of Postal and Telecommunications Administrations (CEPT) and which is implemented by the most European countries. There exist following national restrictions (status of May 2001): Bulgaria, Greece, Italy, Poland, Portugal, that require to be further investigated.

Low cost implementation options for IVHW should be given particularly if a GPS positioning module or a navigation system are already installed in the vehicle. In these cases the only hardware component required additionally is the radio communication module. The frequency band chosen allows the dual-use of an already existing GSM-antenna.

The receiver device of the IVHW system can also process warning messages sent by roadside beacons if they comply with the IVHW message protocol; these roadside beacons can either be fixed infrastructure equipments or mobile beacons (these are useful in the case of roadworks for example).

The following use cases are the typical situations for applying Inter Vehicle-Hazard Warning:

## 1.1 Accident

When a car crash sensor is triggered, IVHW messages are automatically sent by the car. This case is very important in order to avoid severe pile-up accidents.

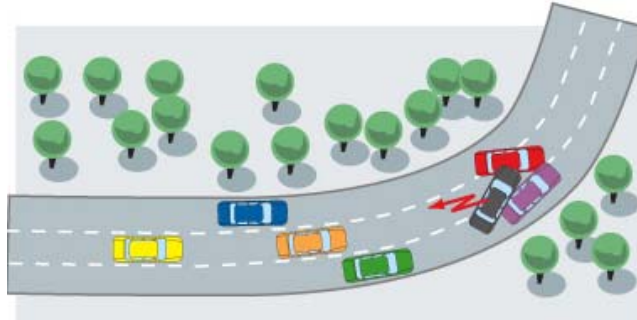

Figure 1-1: A vehicle has an accident and emits a “accident” hazard warning

## 1.2 Generic warning

The vehicle that sends the warning message is located at the end of a queue behind an accident, a traffic jam or a very slow traffic (eg. trucks in a steep slope). It either moves at slow speed or stops and its warning flashers are activated.

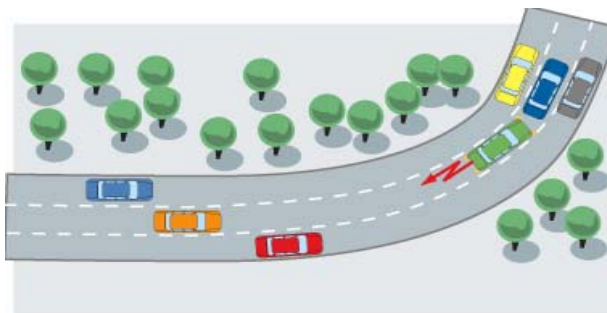

Figure 1-2: A driver in a dangerous situation emits a generic hazard warning.

## 1.3 Stopped vehicle

The vehicle that sends the warning message has stopped on the emergency lane. It uses IVHW to set up a „virtual warning triangle“ at its location to warn the following traffic. To activate IVHW the driver has to activate the warning flashers first.

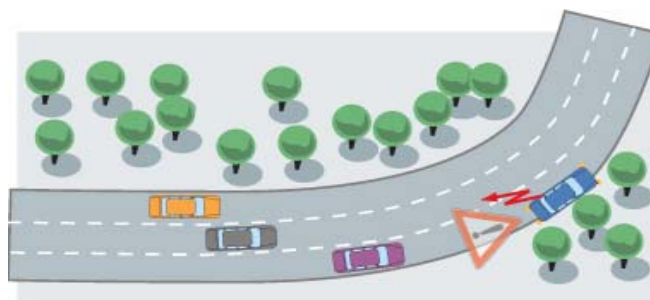

Figure 1-3: A stopped vehicle emits a “stopped vehicle” hazard warning

## 1.4 Warnings emitted by infrastructure beacons

This section describes how the infrastructure can transmit and receive warning messages to or from drivers within the IVHW system. This interface with infrastructure based systems is relevant in case of a low equipment rate during a transition period to a fully IVHW deployment, or in case of light traffic conditions. Furthermore, the reception of the vehicle emitted IVHW messages is an additional source of information for the infrastructure operator to detect more promptly incidents on the network and then to be able to inform drivers about these events.

The infrastructure warning system is composed of an emitter/receiver module similar to those fitted in vehicles but possibly without a GPS device for the fixed equipments (this depends on the availability of a GPS mapping the concerned road).

It will be integrated for instance, in the structure of emergency phone call boxes or in mobile infrastructure beacons (possibly used for example for the roadworks use case).

The infrastructure beacon system has two communication interfaces:

- a wireless one (IVHW) to transmit warning messages to IVHW vehicles with an adaptive emitting power
- a fixed connection (likely a fibre optic connection) to the Traffic Information Centre (TIC) in order to transmit the events received from IVHW vehicles and also to receive instructions from the TIC.

A dedicated application has to be developed in the TIC. This server with an HMI shall decode messages transmitted by the roadside emergency warning module.

In the 'Uplink' mode (IVHW vehicles to roadside IVHW system to TIC), the messages transmitted are in GPS co-ordinates format and shall be decoded on the HMI of the server in XY format with the following attributes: motorway identifier, direction, location and type of incident.

In the 'Downlink' mode (TIC to infrastructure module to equipped vehicles), the application server sends the position of the incident and not the position of the roadside module. Consequently, the on-board IVHW system in the vehicle shall be able to decode the message sent by the application server and which contains the incident position regarding the roadside module location known by the server.

A priority mechanism should be applied in the application server during the receiving phase. It will be consistent with the hazard type numbering implemented in the on-board IVHW devices.

After reception of IVHW messages coming from a vehicle through the infrastructure network, the TIC operator can manually trigger the warning message transmission by other IVHW roadside modules located upstream of the event, if necessary. In addition, the TIC server will generate messages thanks to the information gathered with the other systems like Automatic Incident Detection tools (cameras, radar,..), patrol vehicles, phone calls, etc... These infrastructure generated messages will be reserved to severe situations in order to preserve the radio channel from irrelevant use. Besides the infrastructure beacons shall use a set of different broadcast powers adapted to each situation (in example, in some cases a emitted power of 10mW, or 50mW should be enough).

The deactivation of the emission of the infrastructure based messages are done on the same basis as the messages emitted by the vehicles as far as the channel protection is concerned. Otherwise it will dependent on the TIC road management algorithms.

The messages transmitted by the emergency roadside module are identified as such and differentiated from the messages sent by vehicles.

The following use cases are the typical situations for applying Inter Vehicle-Hazard Warning from an infrastructure beacon:

### 1.4.1 Accident

This message is emitted by the closest upstream infrastructure beacon when the motorway operator has detected an accident. The traffic situation is the same as in the case of a vehicle emitting the message.

### 1.4.2 Generic warning

This message is emitted by the closest upstream infrastructure beacon when the road operator has detected a very dangerous situation of a miscellaneous kind, other than an accident, a stopped vehicle, roadworks etc... This message can thus be used in case for example of an object on a traffic lane, a demonstration etc...

### 1.4.3 Stopped vehicle

This message is emitted by the closest upstream infrastructure beacon when the road operator has detected a stopped vehicle accident. The traffic situation is the same as in the case of a vehicle emitting the message.

### 1.4.4 Roadworks

This message is emitted by the closest upstream infrastructure beacon (or by a dedicated mobile beacon) when there are dangerous roadworks on the road.

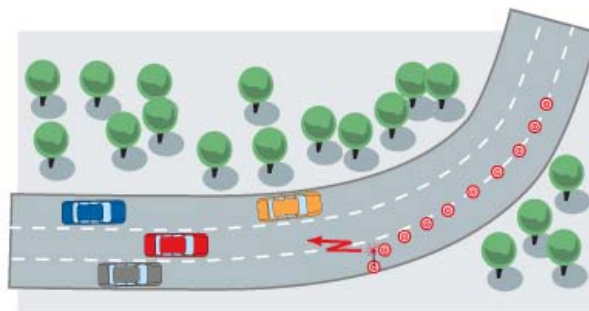

Figure 1-4: An infrastructure beacon emits a “roadworks” hazard warning.

### 1.4.5 Traffic congestion

This message is emitted by the closest infrastructure beacon when the road operator has detected a traffic congestion which is characterized on a motorway by a location with vehicles driving with speeds inferior to 40km/h.

### 1.4.6 Very slippery road

This message is emitted by the closest infrastructure beacon when the road operator has detected a very slippery road part. This is characterized by an actual visual identification of a dangerous slippery area by a motorway service patrol.



#### **1.4.7 Heavily reduced visibility**

This message is emitted by the closest infrastructure beacon when the road operator has detected a road part with a heavy reduced visibility. This is characterized by a visibility distance inferior to 150m.

#### **1.4.8 Vehicle on wrong carriageway**

This message is emitted by the closest upstream infrastructure beacon when the road operator has detected a vehicle on the wrong carriageway on a road where the two directions of traffic are physically separated. This case is very rare but then extremely dangerous.

## 2. Issues for standardization

IVHW components such as driver interface, CAN-bus connection etc. can be realized by each car manufacturer specifically according to his needs and preferences. However, in order to ensure interoperability with other vehicles, structure and size of the warning message and the data transmission techniques deployed for IVHW need to be the same.

In the following the specifications of these issues which have been developed in the DEUFRAKO project are compiled. These specifications are considered by the consortium as a basis for consensus formation amongst all European car manufacturers.

### 2.1 Message structure and size

#### 2.1.1 Overview table

Variable	Size (bit)
Preamble	144
Start	8
Header	8
Random-Message ID	9
Road type	3
Road ID	24
Hazard type	5
Current speed	5
Position and trace data	155
Error Correction	84
<b>Total message size</b>	<b>445</b>

Table 2-1: IVHW message content overview

#### 2.1.2 Message sections content description

##### 2.1.2.1 Preamble

Size: 144 bits

Pattern of 0011... for synchronization. *The possible use of GPS time for synchronization instead of a synchronization pattern is to be discussed.*

##### 2.1.2.2 Start

Size: 8 bits

Indicator for the beginning of the message (00011011)

##### 2.1.2.3 Header

Size: 8 bits

Each IVHW Message starts with a fixed header in order to recognize it as IVHW message.

The pattern is 01101011.

#### **2.1.2.4 Random-Message-ID**

Size: 9 bits

If one vehicle transmits an IVHW-Message consecutively several times with the same content, each of the received messages would be displayed to a driver although only the first one provides new information. With the random message-ID consecutive messages with the same content may be suppressed in the receiving vehicle. We suggest a size of 9 bits in order to distinguish between 512 different message-IDs.

As the ID is randomly assigned to the vehicle whenever the engine is started, the random-message-ID cannot not be abused for tracking vehicles.

#### **2.1.2.5 Road-Type**

Size: 3 bits

information on road-type may be derived from digital maps or advanced software algorithms evaluating speed and course profile. 3 bits are coding 8 different road types:

Road-Type	Description
000	Motorway
001	Rural road
010	Urban road
110	information not available
others	tbd

**Table 2-2: Assignment of road-type code**

**2.1.2.6 Road-ID**

Size: 24 bits

The Road ID consists of: four characters of six bits each indicating the European code name of the road (e.g. "E146")

The table below shows the 6 bits representation of the relevant characters.

IV HW	ASCII		C	IV HW	ASCII		C	IV HW	ASCII		C	IV HW	ASCII		C
	(dec)	(dec) (car.)			(dec)	(dec) (car.)			(dec)	(dec) (car.)			(dec)	(dec) (car.)	
0	0	NUL	\0	1	7	BEL	\a	2	9	HT	\t	3	10	NL	\n
4	32	SP		5	33	!		6	34	"		7	35	#	
8	36	\$		9	37	%		10	38	&		11	39	'	
12	40	(		13	41	)		14	42	*		15	43	+	
16	44	,		17	45	-		18	46	.		19	47	/	
20	48	0		21	49	1		22	50	2		23	51	3	
24	52	4		25	53	5		26	54	6		27	55	7	
28	56	8		29	57	9		30	58	:		31	59	;	
32	60	<		33	61	=		34	62	>		35	63	?	
36	64	@		37	65	A		38	66	B		39	67	C	
40	68	D		41	69	E		42	70	F		43	71	G	
44	72	H		45	73	I		46	74	J		47	75	K	
48	76	L		49	77	M		50	78	N		51	79	O	
52	80	P		53	81	Q		54	82	R		55	83	S	
56	84	T		57	85	U		58	86	V		59	87	W	
60	88	X		61	89	Y		62	90	Z		63	12	NP	\f

**Table 2-3: 6 bits representation of the relevant characters**

**2.1.2.7 Current Speed**

Size: 5 bits

The speed information to be transmitted is not required to be very accurate. Therefore, it will be coded by 5 bits, resulting in a speed resolution of 2m/s with a representable maximum speed of 62m/s (223km/h). If speed is higher, the maximum value has to be transmitted.

Current Speed	Scaling and resolution
5 bits unsigned Integer	current speed value in m/s divided by 2; limited to the maximum value of 31; Resolution is 2m/s (7,2km/h) per unit

**Table 2-4: Current speed field**

**2.1.2.8 Hazard Type**

Size: 5 bits

The hazard type will be specified by a 5 bits number as specified by the following table:

Hazard Type	Description	Emitter
00000	Accident	Vehicle
00001	Generic warning (also used for "undefined")	Vehicle
00010	Stopped vehicle	Vehicle
00011	Accident	Infrastructure
00100	Generic warning (also used for "undefined")	Infrastructure
00101	Stopped vehicle	Infrastructure
00110	Road works	Infrastructure
00111	Traffic congestion	Infrastructure
01000	Very slippery road	Infrastructure
01001	Heavily reduced visibility	Infrastructure
01010	Vehicle on wrong carriageway	Infrastructure
Others	tbd	

**Table 2-5: Hazard types**

**2.1.2.9 Position and trace data**

Size: 155 bits

In order to detect if a received hazard message is relevant to the driver, information about the current position of the sender along with a direction information and a chain of previously passed positions are transmitted. One of these is the position where the warning has been activated.

A suggestion for an algorithm for the generation of previously passed positions can be found in [Mezg2001]

### Sub-structure of position and trace data section

The following table shows the position and trace data block as explained in the subsequent chapters:

Description	Size (bits)
Longitude current position	15
Latitude current position	14
Current heading (2.8 deg/bit)	7
Matched position indicator	1
Activation position indicator	3
$\Delta$ longitude (“ $\Delta$ lon”) trace position 1	12
$\Delta$ latitude (“ $\Delta$ lat”) trace position 1	11
$\Delta$ longitude_trace position 2	12
$\Delta$ latitude trace position 2	11
$\Delta$ longitude trace position 3	12
$\Delta$ latitude trace position 3	11
$\Delta$ longitude trace position 4	12
$\Delta$ latitude trace position 4	11
$\Delta$ longitude trace position 5	12
$\Delta$ latitude trace position 5	11
<b>Total</b>	<b>155</b>

**Table 2-6: Sub-structure of position and trace data section**

#### 2.1.2.9.1 Current position

The first information in the position section describes the current latitude, longitude (WGS84 coordinates, see [WGS84]) and heading angle. “Current” means that the most recent, valid measurements before transmission shall be used.

Although the current position shall describe an absolute position on earth the latitude, longitude information may be encoded more compactly by using a relative positioning concept between sender and receiver. This is possible because the message can only be received within a maximum distance of some kilometers around the sender. The high order digits of the longitude, latitude values of the sender can be omitted as they are similar on the receiver side. The absolute position can be easily restored at the receiver side using its own position.

The coding scheme for longitude, latitude and the algorithm for restoring the sender's absolute WGS84 position on the receiver side are described in A.1 and A.2.

### 2.1.2.9.2 Current heading

The current heading value is intended to be used for discriminating messages from the opposite driving direction without need for matching. The heading value may be derived from the GPS north angle directly if the vehicle is driving with reasonable speed. When stopped the GPS angle will be a random value so that the heading angle must be derived from two position measurements taken at reasonable distance from each other (ca. 30m).

Current heading	Scaling/Resolution
7 bits unsigned Integer	North angle (in deg., clockwise) as measured, multiplied by 128/360; Resolution: 2,8 bit per unit

**Table 2-7: Current heading**

### 2.1.2.9.3 Activation position indicator

In order to let the receiver know where the IVHW has been activated, this position will be immediately cast as a trace point, included into the chain and marked as the activation position.

In a separate 3-bits-field the index of the activation position will be noted - the meaning is as follows:

Activation pos. indicator	Meaning
0	activation occurred at current position
n=1..5	activation occurred at trace point n
7	activation was before trace point 5 and is now outside representation range

**Table 2-8: Activation position index notes trace point where activation occurred**

The casting of points is continued after the warning activation has occurred. Since the oldest trace point is discarded every time a new one is cast, this would result in a possible loss of the activation position (when it happens to be the last point of the chain). In order to keep the activation position over a longer distance, it is proposed to change the chaining operation when the activation position coincides with the 5<sup>th</sup> point. In that case, with the addition of a new trace point, the older points are shifted through only until point 4 which is discarded (instead of point 5 which is the activation position to be kept).

However, because of the relative distance coding (see ANNEX A) this can only be handled over a limited distance. In the worst case this distance will be 1,6km plus chain length up to trace point 4.

The mentioned loss of the activation point is not really a problem for the warning functionality since in that case the activation point lies already outside the sender's communication range: The receiving vehicle will in any case have passed the activation position when receives the message. For information, the fact that the activation position fell out of range is marked in the activation position indicator by a special value (see table below).

**2.1.2.9.4 Matched position indicator**

It is useful for interpretation of a warning message to know if the trace has been produced by map matched positions (from navigation system) or just a GPS coordinate (For simple systems without digital maps). The matched position bit shall encode this condition:

Matched Position bit	Meaning
0	0 - Position value from GPS only equipment 1 - Position value from map matched position

**Table 2-9: Matched position indicator**

**2.1.2.9.5 Previous positions (trace points)**

As previously mentioned not only the current, but also previous positions (called “trace points” in this document) shall be transmitted in order to enable better message relevance determination on the receiver side, thereby lowering false alarm rates. This also applies if the receiver does not have a digital map, but only current and past GPS information (GPS only, e.g. ETC trucks).

The trace point chain is proposed to consist of five additional positions marking the past vehicle trace, one of them being the position where the warning has been activated (see figure below). In order to represent a maximum of information, each of these trace points has to be selected on the sender side according to a set of casting rules. A suggestion of such rules is described in [Mezg2001].

The previous trace points shall not exceed a relative distance between consecutive points. Their positions are coded in a relative position scheme having the current position as the starting point of the chain.

For the trace point position coding consider the following figure

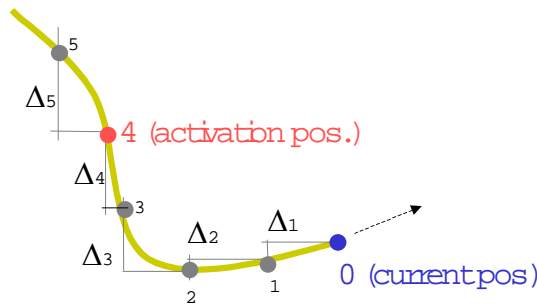

**Figure 2-1: Current position and past trace points with relative position coding**

In the message the past trace point data are sequenced in reverse order - current position first, then immediately preceding trace point (1) etc. For the relative position coding, one trace point is coded relative to its predecessor, i.e. trace point position 1 is coded as the difference relative to the current position etc. Again, the differences are directly coded as  $\Delta_{lat}$ ,  $\Delta_{lon}$  pairs and should have the same resolution as the current position values.



For the IVHW application it is assumed that a 1,6km distance between two trace points should be sufficient for the trace representation, resulting in an 11bits value for  $\Delta\text{lat}$  and 12 bits for  $\Delta\text{lon}$ .

This coding scheme limits the distance range of consecutive trace points and requires that the point casting algorithm must place the next trace point when the representation limit is reached (see [Mezg2001]).

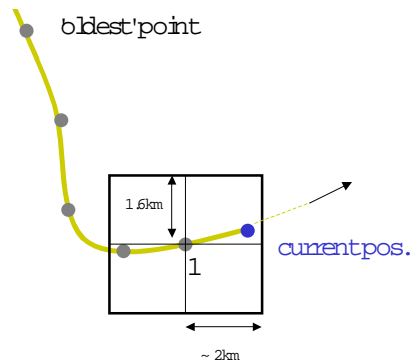

**Figure 2-2 : Position chain with relative coordinate systems**

Consider the situation where Pos 1 is fixed as the last trace point. Before the continuously tracked vehicle position exceeds the drawn rectangle, a new trace point has to be stored in the chain in order to not exceed the representable position range.

The maximum backward span of the trace would be about 8km in one dimension, but will be shorter for most real circumstances. Note for calculation of angle differences there is a wrap between +180deg. and -180deg longitude (however, as this is east Siberia and pacific ocean, probably not relevant for typical IVHW application regions).

Trace Position (i)	Coding / Resolution
$\Delta\text{latitude}$ (11 bits) signed integer ("Δlat")	Difference in deg. latitude relative to previous trace point (i-1), or to current position for i=1 scaled by 32768 and limited to $\pm 1023$ Resolution: $2^{-15}$ deg or 3,4m per unit
$\Delta\text{longitude}$ (12 bits) signed integer ("Δlon")	Difference in deg. longitude relative to previous trace point (i-1) , or to current position for i=1 scaled by 32768 and limited to $\pm 2047$ Resolution: $2^{-15}$ deg or $3,4\text{m} \cdot \cos(\text{lat})$ per unit

**Table 2-10: Content for the 5 trace position pairs**

### 2.1.2.10 Error coding

Size: 84 bits

Reed Solomon FEC. Description see ANNEX B.

*To be discussed.*

## 2.2 Transmission techniques

### 2.2.1 Requirements

The basic requirements of the communication module result from the features of the IVHW application listed in the following table:

Parameter	Requirement
Communication distance	at least 1 km, also without line of sight, only single hop, no retransmission
Communication mode	broadcast, selection of the relevant messages will be done by the receiver
Message repetition rate	0,5 s
Advance warning time	5-10 s before the receiver reaches the hazard location (1)
Communication fee	no costs for transmission of warning messages
Permission area	Europe
Positioning method	GPS

**Table 2-11: Basic requirements of the communication module**

Note 1: For a vehicle going with 250 km/h (69,4 m/s) an advance warning time of 5 – 10 s results in a distance of 347 – 694 m. This is still below the communication distance of 1000 m.

### 2.2.2 Hardware specification

There exists a European frequency band at 869.4 - 869.65 MHz (ISM-Band) for non-specific short range devices with a maximum transmission power of 500 mW e.r.p.. The channel spacing is 25 kHz. For high speed data transmission also the whole frequency band may be used. This license free frequency band is a well suitable basis of a communication module, which fits the requirements of the IVHW system.

Parameter	Value
Frequency band:	869.4–869.65MHz ISM band
Bandwidth/Channel:	25 kHz
Transmission power:	500 mW e.r.p
Licence:	no licence fee
Type approval:	free circulation
Duty cycle:	< 10 %
Max. cont. transmission:	36 s
Modulation	GMSK

**Table 2-12: ERC recommendation 70-03 relating to the use of short range devices**

Parameter	Specification
Central frequency:	869.6375MHz (from the 869.4–869.65MHz ISM Band)
Bandwidth/Channel:	25 kHz (869.625-869.650MHz)
Antenna-type	Omnidirectional
Communication mode:	Half-Duplex, always listening, while not sending
Switching delay:	<10 ms
Channel access:	Carrier sense, random delay
Datarate on air:	>10 kbit/s
Error protection:	Reed Solomon FEC
Channel coding	NRZ

**Table 2-13 : Technical specification of the radio module**

### 2.2.3 Existing Regulations

The basic conditions for the use of the ISM frequency band at 869.4 - 869.65 MHz are defined in [CEPT], which is implemented by the most European countries. The following national restrictions do exist (status August 2001) :

Country	Implementation	Use
Bulgaria	Not implemented	
Estonia	Voice, audio and video only on frequencies above 2.4 GHz	
Germany	Transmission of audio and voice signals excluded	
Greece	Not implemented	Government use
Italy	Max 25 mW erp	Military applications
Latvia	ERP < 10 mW	
Poland	Not implemented	WLL usage, Implementation planned

**Table 2-14: National restrictions**

In France and Germany the national authorities decide mainly in line with the [CEPT]. The national regulations are published in the following documents:

France [ART1999]

Germany [RTP1999a], [RTP1999b] [RTP2000]

The whole bandwidth (869.4 – 869.65 MHz = 250kHz) may be used for “high speed data transmission”. As discussed with the German regulation authorities, using the whole bandwidth in one channel should provide a data rate which is equal to the sum of all channels.

### 2.2.4 Channel access

In the idle state all IVHW radios will be in the receive mode to be prepared for the reception of warning messages. Normally, there will be no traffic on the radio channel. But if a warning event occurs, several vehicles will try to send warning messages. Especially if there is an accident with airbag release the affected vehicles will initiate the transmission of warning messages exactly at the same time. There is a strong need to regulate the access to the RF medium not to block the channel by collisions.

To overcome the problem of simultaneous channel access following collision avoidance strategy will regulate the access to the RF medium:

1. A radio, which is not transmitting, should always listen the radio channel to receive possible warning messages of other transmitters.
2. A radio wanting to transmit a warning message starts doing a carrier sense to check whether the RF medium is busy. The RF medium is considered to be free if the input power is below a certain level for a randomly selected duration. The different duration of the carrier sense will avoid the problem with the simultaneous automatic activation after an accident. *Both parameters, the time frame for the carrier sense and the level of sensitivity of the carrier sense are tbd.* The required level of sensitivity depends on the communication range of the radios and on the traffic on the radio channel caused by other applications using the same frequency. The duration has to be limited to a certain period of time in order to prevent the system from internal hook-up.
3. If no carrier is sensed for the randomly selected duration, the radio starts immediately with the transmission of the warning message. After that the radio will switch back to the receive mode.
4. If a carrier is sensed, the radio will go on doing carrier sense until the RF medium is free for the randomly selected duration. Then the procedure goes on with step 3.

### 2.2.5 Message transfer

In the idle state the communication module will be in the receive mode. All received correct warning messages will be passed to the IVHW controller. Corrupted messages will be discarded.

On request the communication module starts with the periodical transmission of a warning message. The period for retransmission is 0.5s. Each transmission starts with the channel access procedure described in 2.2.4 above. The retransmission of a warning message will be stopped on request.

### 2.2.6 Error protection

The transmission of warning messages is done in a broadcast modus. Therefore ARQ-procedures for error correction are not possible.

FEC-techniques consume a considerable portion of the channel capacity. The selection of a proper FEC-procedure for IVHW requires an exact knowledge about the statistical error behaviour of the radio channel. For IVHW a Reed Solomon FEC has been chosen, see ANNEX B

### 2.2.7 Conclusion

The specification of the communication module is strongly related to the commercially available modems and components in the same or similar frequency bands. This enables the usage of

widely-used RF-components for reasonable costs. Also the time until first prototypes for field tests will be available can be reduced significantly.

The physical architecture will depend on each manufacturer.

## 2.3 Standardised icons for in-vehicle display

The HMI will depend on each manufacturer. Nevertheless, to ensure a common understanding of each critical situations in all vehicles some standardised icons are proposed. These icons were designed with 64x64 pixels.

This proposal doesn't imply that a visual HMI is compulsory for the system: in the case a visual display is featured it should use this kind of graphical representation of the situation according to the technical possibilities of the display (without colour for black and white displays for example, or with fewer pixels).

Note: the black square border around the proposed icons is not part of the proposal but just an editorial constraint.

### 2.3.1 Accident



Figure 2-3

### 2.3.2 Generic warning



Figure 2-4

### 2.3.3 Stopped vehicle



Figure 2-5

### 2.3.4 Roadworks



Figure 2-6

### 2.3.5 Traffic congestion



Figure 2-7

### 2.3.6 Very slippery road



Figure 2-8

### 2.3.7 Heavily reduced visibility



Figure 2-9

### 2.3.8 Vehicle on wrong carriageway



Figure 2-10

## **3. Terms and definitions**

### **3.1 Abbreviations and acronyms**

ARQ	Automatic Repeat Request / Query
ART	Agence de Régulation des Télécoms (Telecommunications Regulation Agency, France)
CEPT	Conférence Européenne des Postes et Telecommunications (European Conference of Posts and Telecommunications)
ERC	European Radiocommunications Community
FEC	Forward Error Correction
GPS	Global Positioning System
GSM	Global System for Mobile communication
HMI	Human Machine Interface
IVHW	Inter Vehicle Hazard Warning
OEM	Original Equipment Manufacturer
TIC	Traffic Information Centre

## **4. References**

- [ART1999] ART 99-567
- [CEPT] European Conference of Postal and Telecommunications Administrations: ERC Recommendation 70-03
- [Mezg2001] Dr. Mezger, Klaus; Passegger, Thomas: IVHW Trace Point Casting Algorithm. Daimler-Chrysler AG Contribution to IVHW WP1; project deliverable 2001.
- [RTP1999a] Vfg 81/1999 (Amtsblatt Reg TP Nr. 12/99)
- [RTP1999b] Vfg 123/1999 (Amtsblatt Reg TP Nr. 14/99)
- [RTP2000] Vfg 52/2000 (Amtsblatt Reg TP Nr. 9/00)



## ANNEX A Detailed description of position encoding scheme

### A.1 Position encoding on sender side

The scheme for the low order coding of the current position (see 0), latitude and longitude of the sender is described in this section, followed by the decoding scheme on the side of the receiver.

Step	Operation (latitude)	Value-range	Resolution
1	Input WGS84 latitude value, convert to decimal degrees float number	$\pm 90^\circ$ $\pm dd.ddddd$	should be in the order of 10 $\mu$ deg or 10" (arc seconds)
2	multiply by scale factor 32768 ( $=2^{15}$ )	within $\pm 10^7$ or $\pm 2^{22}$	unchanged
3	convert to 32-bit integer value	unchanged	unit corresponds to $2^{-15}$ deg ( 3,4m )
4	extract low order 14 bits for transmission	$+2^{14}$ corresponding to a north-south range of 55km or $\pm 23$ km max. relative distance sender - receiver	unchanged

**Table A- 1: Latitude coding for current position**

For the longitude value representation an additional bit is proposed as explained above. Except for this detail, the coding framework is essentially the same

Step	Operation (longitude)	Value range	Resolution
1	Input WGS84 longitude value from source, convert to decimal degrees float number	$\pm 180^\circ$ $\pm ddd.ddddd$	should be in the order of 10 $\mu$ deg or 10" (arc seconds)
2	multiply by 32768 ( $=2^{15}$ )	within $\pm 10^7$ or $\pm 2^{23}$	unchanged
3	convert to 32-bit integer value	unchanged	unit corresponds to $2^{-15}$ deg, or $3,4m \cdot \cos(\text{lat})^*$
4	extract low order 15 bits for transmission	$+2^{15}$ corresponding to east-west range of $\pm 55\text{km} \cdot \cos(\text{lat})^*$ max. relative distance sender - receiver	unchanged

\* for central europe at  $50^\circ$  latitude the  $\cos(\text{lat})$  factor is approximately 0.64

**Table A- 2: Longitude coding for current position**

### A.2 Position decoding on receiver side

As mentioned in 0, the sender transmits only the  $n$  least significant bit parts (**a**) of the lat/lon values of his own position (referenced as **Aa**), since the high order part of sender and receiver

at most differ by  $\pm 1$  in the value bit  $n$ . The number  $n$  of bits has been chosen so that the representable range of  $\pm 2^{n-1}$  distance units is greater than the communication range.

The following table shows the steps for regeneration of the sender's absolute position value **Aa** on the receiver's side by means of the receiver's complete position **Bb** and the transmitted low order part **a**.

Step	Operation (latitude)	Value range
1	Input low order 14 bits from transmitted message <b>a</b> From own latitude <b>Bb</b> extract low order 14 bits <b>b</b>	$+2^{14}$
2	wrap low order values ... if $(a-b) \geq 2^{13}$ then $a = a - 2^{14}$ if $(b-a) \geq 2^{13}$ then $b = b - 2^{14}$	<b>a</b> and <b>b</b> within $\pm 2^{13}$
3	calculate absolute latitude <b>Aa</b> by $Aa = Bb + a - b$	full latitude range

**Table A- 3: Regeneration of sender latitude on receiver side**

The algorithm is the same for longitude with exception of the values depending on the bit count  $n$ , since the longitude message is designed with 15 instead of 14 bit size.

Step	Operation (longitude)	Value range
1	Input low order 15 bits from transmitted message <b>a</b> From own latitude <b>Bb</b> extract low order 15 bits <b>b</b>	$+2^{15}$
2	wrap low order values ... if $(a-b) \geq 2^{14}$ then $a = a - 2^{15}$ if $(b-a) \geq 2^{14}$ then $b = b - 2^{15}$	<b>a</b> and <b>b</b> within $\pm 2^{14}$
3	calculate absolute longitude <b>Aa</b> by $Aa = Bb + a - b$	full longitude range

**Table A- 4: Regeneration of sender longitude on receiver side**

## ANNEX B Reed Solomon Coding

### B.1 Reed Solomon Parameters

RS parameters depend on data rate and partition level.

RS\_B : number of bit in a RS symbol

RS\_N : number of RS symbols in a RS codeword

RS\_K : number of RS symbols in a RS codeword that contain information bit

### B.2 Basic Reed Solomon Encoder

In the following the basic RS encoder is described to form the RS code RS(N,K) with N code symbols and K information symbols per codeword. The number of bit per RS symbol (RS\_B) determine the order of the Galois Field (GF) that is used for RS coding. A GF is described by a primitive polynomial of degree RS\_B.

A RS symbol with RS\_B bit can be interpreted as

- integer number in the range  $0 \dots 2^{\text{RS}_B} - 1$ .
- vector of RS\_B bit, i.e. the binary representation of the integer number from 1.
- polynomial with binary coefficients with degree  $< \text{RS}_B$ .

The least significant bit (LSB) of a RS symbol corresponds to the constant term of the polynomial representation. RS symbols are transmitted with most significant bit (MSB) first. RS\_symbols are added and multiplied using  $\text{GF}(2^{\text{RS}_B})$  arithmetic, i.e. with polynomial addition and multiplication whereas the coefficients are added and multiplied with binary arithmetic. The result is taken modulo the primitive polynomial  $p(x)$ .

The basic RS encoder uses RS symbols as coefficients for a polynomial representation of a sequence of RS symbols. The RS symbols  $a_0, g_0, r_0$  and  $c_0$  are the first RS symbols in time. Now the formal parameter X is used to describe sequences as polynomials whereas previously the formal parameter x has been used to describe RS symbols as polynomials.

RS symbols	Polynomial	Degree	Calculated as
generator	$g(X) = \sum_{n=0 \dots N-K} g_n X^n$	N-K	$g(X) = \prod_{i=K \dots N-1} (X - \alpha^{-i})$
information	$A(X) = \sum_{n=0 \dots K-1} a_n X^n$	K-1	
redundancy	$R(X) = \sum_{n=0 \dots N-K-1} r_n X^n$	N-K-1	$R(X) = X^{N-K} A(X) \text{ mod } g(X)$
codeword	$C(X) = \sum_{n=0 \dots N-1} c_n X^n$	N-1	$C(X) = X^{N-K} A(X) - R(X)$

**Table B-1: Polynomials for RS encoding**

Encoding of K information RS symbols to N code RS symbols is done with the aid of the generator polynomial  $g(X)$  of degree N-K. The generator polynomial is calculated with the primitive element  $\alpha=2$  (RS symbol in integer representation). The redundancy  $R(X)$  is calculated from the information  $A(X)$  as the remainder of the polynomial division  $X^{N-K} A(X) / g(X)$  such that  $R(X)$  has degree less than N-K. The code word  $C(X)$  is formed by appending the information symbols to the redundancy symbols:

$$C(X) = X^{N-K} A(X) - R(X).$$

The parameters of the RS-Encoder for IVHW are presented in Table B-. The code is able to correct 7 symbols in an IVHW-message. The correction of a symbol is independent of the number of corrupted bits per symbol.

RS_B	RS_N	RS_K	Throuput	Primitive polynomial p(x)
6	56	42	75 %	$x^6 + x + 1$

**Table B-2: RS-encoder for IVHW**

As the result of the above specified RS encoder the redundancy part precedes the information part. After swapping the information and redundancy sequences such that the information sequence (length RS\_K) is followed by the redundancy sequence (length R) the result becomes the form as specified in message format.

## ANNEX C Additional background information on position representation and resolution

For ease of use and applicability it is proposed that all position data shall be expressed in geographic WGS84 coordinates in degrees latitude, longitude (also referred as lat, lon). These coordinates are typically available through all GPS receivers.

The lat/lon position values shall be transmitted as integer values. In order to describe distances in the order of  $10^{-7}$  degrees the original representation must be scaled to an appropriate range. When using the below proposed representation for the position coordinates, a resolution of approx. 3,40m (least significant bit) will result. This seems to be sufficient for IVHW applications, since this value is below current GPS and Map accuracy and is in the order of one Highway lane width.

Whereas for the latitude values, the equivalence between angle and distance on earth surface is around 111km per degree - independent of position on earth, the longitude distance equivalent decreases towards the poles. To calculate the local distance equivalent for longitude, the above value is to be multiplied by the cosine of latitude (see figure below). In order to maintain the same distance ranges in both directions, one more bit is to be spent for the latitude numbers to compensate for this property of geographic coordinates. One extra bit (factor 2) is sufficient for compensation under 'reasonable' latitudes. Alternatively, a variable latitude scaling may be discussed which would result in slightly higher computing effort for scaling and de-scaling on sender and receiver side. The benefit would be a reduction of message length by 6 bits.

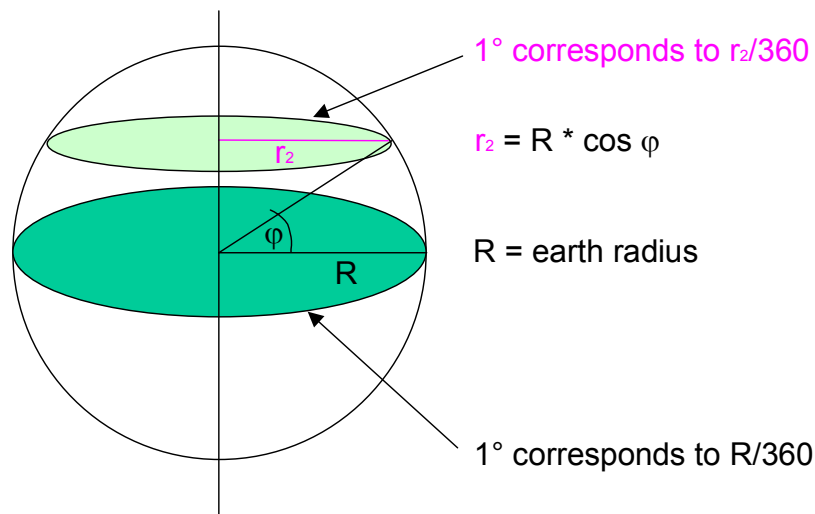

**Figure C-1: Position resolution**

In order to avoid transmission of redundant high order portions of the position values, relative position description schemes are proposed as for the trace points as for the current position.

# IVHW Implementation Issues and Recommendation

Document number:	IVHW del6_draft_v1.doc	
Report number:	Deliverable 6	
Document version:		
Status:	Final	
Dissemination level:	Internal	
Date of preparation:	January 22, 2003	
Authors:	Name	Organisation
Main author	Stefan Abendroth	DC
Contributors	Ina Becker	DC
	WP3.4 partners	

# Table of Contents

<b>1</b>	<b>Introduction.....</b>	<b>5</b>
1.1	The IVHW concept.....	5
1.2	Typical scenarios of use.....	5
1.2.1	Risk of queue and collision.....	5
1.2.2	Vehicle breakdown.....	6
1.2.3	Airbag activation .....	6
1.2.4	Warning from the infrastructure.....	6
1.3	IVHW and accident reduction.....	7
1.4	IVHW implementation .....	8
<b>2</b>	<b>General conceptual approaches.....</b>	<b>9</b>
2.1	Requirements and Restrictions .....	9
2.2	Possible Solutions.....	9
<b>3</b>	<b>Technical options for IVHW realization.....</b>	<b>11</b>
3.1	Communication module using the ISM band (869.4MHz).....	11
3.1.1	Difficulties with the ISM band .....	12
3.1.2	Realizations for ISM communication modules.....	13
3.2	Communication module using FM (87.340 – 87.415MHz).....	14
3.3	Summary on technical options .....	15
<b>4</b>	<b>Standardization issues for IVHW realization .....</b>	<b>16</b>
4.1	Why is standardization necessary? .....	16
4.2	Prototype for demonstration .....	16
4.3	Steps towards a consensus .....	16
<b>5</b>	<b>Market Penetration Scenarios.....</b>	<b>17</b>
5.1	Germany.....	18
5.1.1	Car market.....	18
5.1.2	Car usage pattern .....	19
5.1.3	Trucks.....	20
5.1.4	Navigation systems.....	21
5.1.5	Penetration rates of IVHW on motorways.....	23
5.2	France.....	24
5.2.1	Car market.....	24
5.2.2	Car usage pattern .....	25
5.2.3	Trucks.....	25
5.2.4	Navigation systems.....	25
5.2.5	Penetration rates of IVHW on motorways.....	27
<b>6</b>	<b>Market Entry.....</b>	<b>28</b>
6.1	Market Audit.....	28
6.2	Customer perspective .....	28

6.3 Manufacturer perspective..... 30  
 6.3.1 Market Entry Scenarios..... 33  
**7 Conclusion..... 40**  
**Abbreviations..... 41**  
**References ..... 42**

## List of Figures

Figure 1 : Injury producing accidents in Germany 2000 [5] ..... 7  
 Figure 2 : Injury producing accidents in France 1999 [5]..... 8  
 Figure 3 : IVHW as add-on to a navigation system and/or infotainment unit..... 10  
 Figure 4 : ERC 70-03 band plan for short range devices at 868MHz (Source: Motorola) ..... 12  
 Figure 5 : Layout of a communication module with single chip transceiver device ..... 14  
 Figure 6 : cost estimations for various communication modules (costs per unit for charges of 100 000) ..... 15  
 Figure 7 : new car sales by vehicle segments for Germany [9] ..... 18  
 Figure 8 : segmentation of new car sales in Germany, forecast 2007 [9] ..... 19  
 Figure 9 : equipment rates of navigation systems in Germany (OEM + after market) for new cars and for the total car fleet (Source: Robert Bosch GmbH, 2002)..... 22  
 Figure 10 : ratio of navigation systems in total car fleet for different vehicle segments (estimation)..... 22  
 Figure 11 : penetration rate of IVHW on German motorways within five years from market introduction (estimation) ..... 23  
 Figure 12 : new car sales by vehicle segments in France [9] ..... 24  
 Figure 13 : segmentation of new car sales in France, forecast 2007 [9]..... 25  
 Figure 14 : equipment rates of navigation systems in France (OEM + after market) for new cars and for the total car fleet (Source: Robert Bosch GmbH, 2002)..... 26  
 Figure 15 : ratio of navigation systems in total car fleet for different vehicle segments (estimation)..... 26  
 Figure 16 : penetration rate of IVHW on French motorways within five years from market introduction (estimation) ..... 27  
 Figure 17 : PEST analysis of factors relevant for IVHW ..... 28  
 Figure 18 : SWOT analysis of IVHW ..... 29  
 Figure 19 : three phases of IVHW market penetration ..... 29  
 Figure 20 : positive feedback of network externalities ..... 30  
 Figure 21 : business model for IVHW..... 31  
 Figure 22 : estimation of IVHW systems distributed per year in Germany and France ..... 32  
 Figure 23 : cost index of IVHW versus number of units..... 32



---

Figure 24 : annual cash flows for scenario “All expectations met” .....	34
Figure 25 : cumulated discounted cash flow for scenario “All expectations met” .....	34
Figure 26 : annual cash flows for scenario “High customer acceptance” .....	35
Figure 27 : cumulated discounted cash flow for scenario “High customer acceptance” .....	35
Figure 28 : annual cash flows for scenario “Low customer acceptance” .....	36
Figure 29 : cumulated discounted cash flow for scenario “Low customer acceptance” .....	37
Figure 30 : annual cash flows for scenario “Low cost solution” .....	37
Figure 31 : cumulated discounted cash flow for scenario “Low cost solution” .....	38
Figure 32 : annual cash flows for scenario “Public financing” .....	39
Figure 33 : cumulated discounted cash flow for scenario “Public financing” .....	39

# 1 Introduction

## 1.1 The IVHW concept

IVHW, Inter-Vehicle Hazard Warning, is a system allowing a driver on a motorway or a highway who spots a hazard or feels in a hazard situation to warn upstream drivers well before they reach the affected zone. Typically, the IVHW concept aims at extending the range of vehicles flashing hazard warning lights in order to be more effective. As the system is 'intelligent', only drivers who would be affected will receive the warning message.

The IVHW system aims at reducing accidents caused by drivers being unaware of a hazardous situation down the road. In cases such as poor visibility, the risk of severe traffic accidents is well above average. Driver hazard warning using direct vehicle-to-vehicle communication will improve traffic safety under these circumstances.

The system is based on vehicle to vehicle radio communication with a range of at least 1000m. The system is activated manually by drivers and is coupled with the vehicles hazard warning lights. It is also coupled with airbags so that it can be activated automatically in the event of an airbag being inflated during an accident.

## 1.2 Typical scenarios of use

Basically, the IVHW system is used as a virtual warning flasher on motorways and highways, i.e. when the driver thinks that the situation is such that approaching traffic should be warned [6].

### 1.2.1 Risk of queue and collision

On a motorway with a high traffic density, the traffic is generally flowing in platoons in which headways are generally below the safety interval. It is very likely that in these conditions a minor driving error immediately creates urgent sharp braking, a reduction in overall traffic speed, and queues. If the driver of a vehicle at the end of the queue activates the warning flashers, an immediate warning is sent to the upstream drivers. Thus, by extending the range of today's warning flashers beyond the line of sight, IVHW reduces the risk of queue end collisions. Even if not all vehicles are equipped, combination of IVHW and warning flashers improves the warning impact.

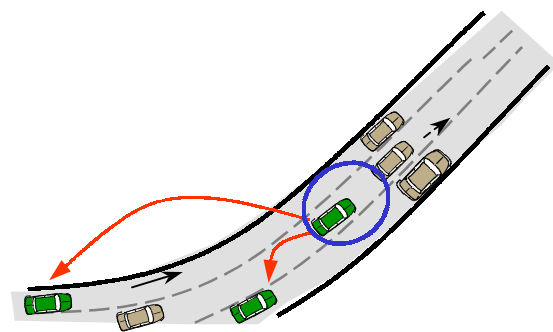

### 1.2.2 Vehicle breakdown

In case of a breakdown, parking on the hard shoulder presents a potentially dangerous situation: the stopped vehicle may very often encroach onto parts of the carriageway or be hidden by a curve or a dip. This presents a high risk of collision with other vehicles, even if the driver activates the hazard warning lights (if they are operational). Installing a warning triangle on the hard shoulder can also be very risky in some situations. In this case, IVHW can send a warning message indicating that there is a broken down vehicle downstream.

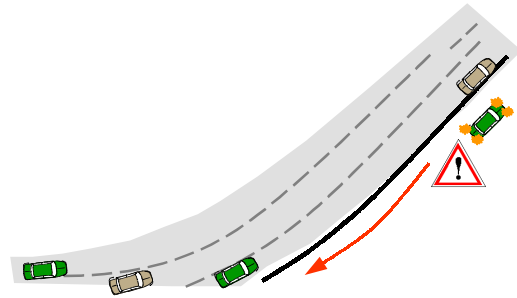

### 1.2.3 Airbag activation

In case of an accident on a motorway, the first seconds after the collision are very crucial for avoiding secondary pile-up collisions and warn the upstream traffic. Coupling IVHW with airbag release allows an immediate warning and may avoid secondary accidents.

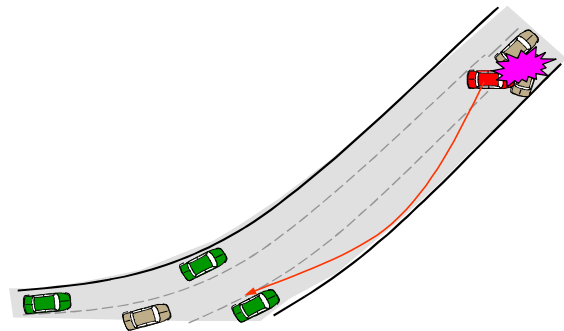

### 1.2.4 Warning from the infrastructure

IVHW can also be used by the infrastructure operator to warn drivers in specific temporary hazardous zones such as road works. This can be achieved by integration of the IVHW sender into specific road signposts.

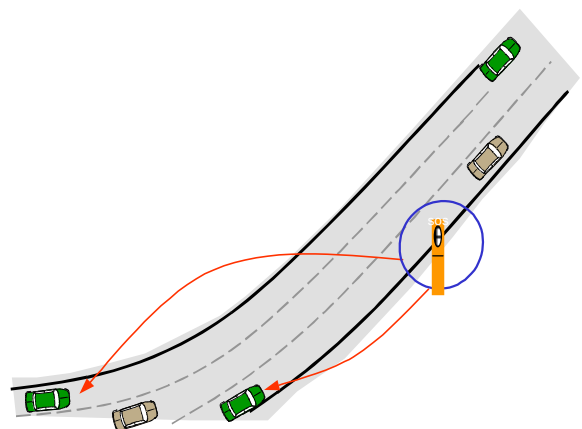



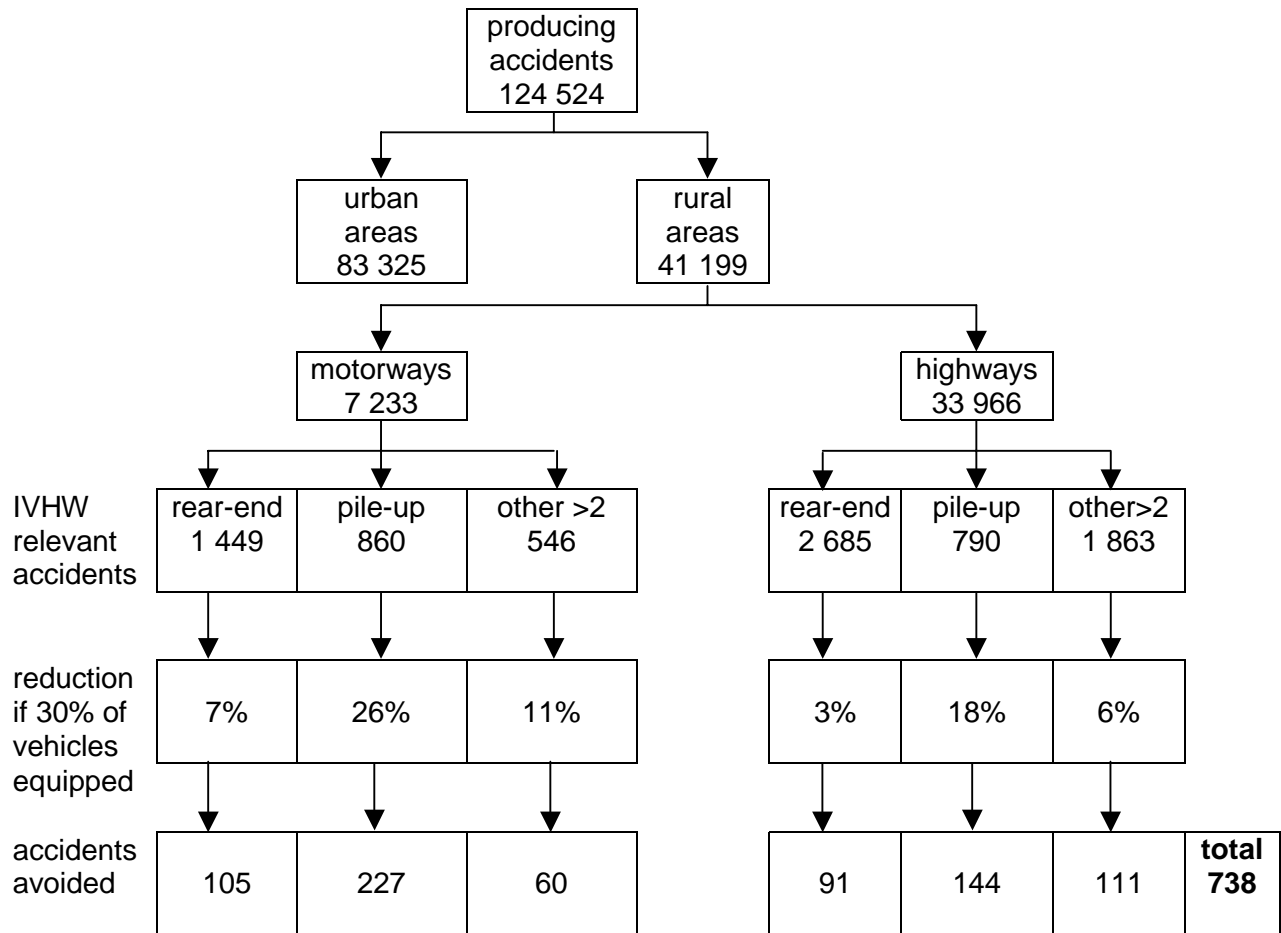

**Figure 2 : Injury producing accidents in France 1999 [5]**

## 1.4 IVHW implementation

The customer benefit of the IVHW system is based on many factors. Only a quick market penetration can ensure the success of IVHW since the functionality of the concept depends on a certain percentage of equipped vehicles on the roads. From a technical point of view, a standardized communication design combined with a convenient vehicle integration and a user friendly human-machine-interface for an acceptable price are indispensable requirements.

Whether the IVHW system can be implemented or not will mainly depend on an appropriate market entry strategy once the technical issues are resolved. A very important parameter in order to determine this strategy are the production, integration, and distribution costs for the IVHW system. Since different alternatives for the system realization have been proposed (e.g. frequency band, antenna, digital map support), they need to be analyzed regarding customer acceptance and potential market penetration rates.

The objective of this document is an estimation of the required costs for various system designs and the evaluation of different market entry scenarios regarding customer safety benefit and manufacturer revenue.

## 2 General conceptual approaches

This chapter gives an overview about the technical concept of IVHW. As a result, the basic approach for the system is outlined, without giving details about the realization of the system.

### 2.1 Requirements and Restrictions

The basic idea of IVHW can be expressed in two steps:

1. To enable the driver of the system to produce a warning message for other vehicles if the actual traffic situation appears crucial to the driver.
2. To generate an appropriate warning for the driver in the vehicles concerned.

The main problem to be solved consists in the transmission of the warning message and in the decision for the receiver of the message whether the corresponding vehicle is affected by the hazard or not.

Affected vehicles are

1. approaching the hazard area
2. within a certain distance
3. with a critical speed
4. on a road or lane which is affected by the hazard.

Those and only those vehicles fulfilling all four conditions should be warned, otherwise we talk about a false warning. False warnings decrease the credibility of the system in the long run and therefore need to be avoided.

The cheapest approach, a simple omni-directional transmitter without any additional information, could only fulfill condition 2 and would produce many false warnings. Conditions 1 and 3 could be checked by a receiver with a frequency reference, measuring a Doppler shift of the received waves towards higher frequencies in case of approaching a hazard area. This requires extremely precise clock references ( $\Delta f/f < 10^{-10}$ ) for electromagnetic waves, which is not feasible for automotive applications. For ultrasonic waves, the Doppler shift would be measurable ( $\Delta f/f \approx 10^{-3}$ ), but condition 2 could not be fulfilled due to the limited range of ultrasound ( $< 1\text{km}$ ).

It is therefore necessary that a generated warning message contains specific information about the position of the vehicle and that a receiving vehicle is able to decide whether it is affected by comparing the message with its own position and speed.

### 2.2 Possible Solutions

The task described above can be solved by using the Global Positioning System (GPS). Since more and more cars are already equipped with a GPS receiver for navigation purposes, this appears to be the most favorable approach for IVHW. In combination with available digital maps and appropriate processing algorithms, the verification of all four conditions for affected vehicles becomes feasible and reliable.

Broadcasting GPS positions requires a digital communication infrastructure. It is a fundamental question whether a cellular infrastructure (like GSM) or a direct inter-vehicle communication is favorable. Due to the fact that only short range communication ( $< 5\text{km}$ ) is

required and operational costs should be avoided, the inter-vehicle approach was fostered in the system specifications.

Since both GPS data source and HMI are already part of every vehicle navigation system and because the IVHW core is mainly a software implementation in order to include the additional functionalities, future navigation systems could be adapted to IVHW with very little vehicle integration costs.

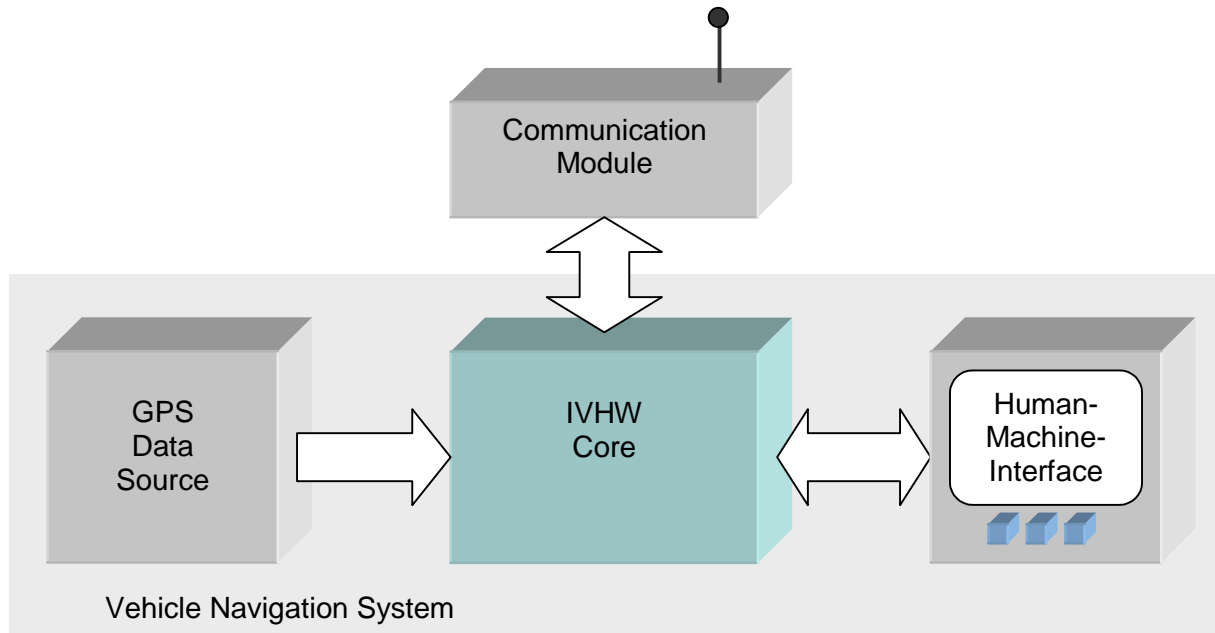

**Figure 3 : IVHW as add-on to a navigation system and/or infotainment unit**

The only hardware component which has to be added for IVHW is the communication module to establish the inter-vehicle message exchange. Obviously, the vehicle integration and the connection of this module will be responsible for the additional costs generated by the introduction of IVHW. It is therefore necessary to analyze the design of this module very carefully and to estimate the costs for both list of materials and vehicle integration for different realization concepts.

One major problem of realizing an IVHW system based on GPS is a decrease in potential market penetration. Today, only few cars are equipped with GPS and an appropriate interface for additional applications (CAN bus). It follows that only new developed cars with navigation module can be equipped with an integrated IVHW. Add-on systems with a GPS module exclusively dedicated to IVHW are very expensive and hard to integrate into an existing vehicle. However, not many additional components are necessary in order to realize an IVHW application on an existing GPS platform.

### 3 Technical options for IVHW realization

The complex question of designing a suitable communication module has been thoroughly discussed in WP1. The following aspects need to be considered:

- carrier frequency
- bandwidth
- modulation
- antenna
- components
- legal issues

Accordingly, there are a couple of major criterions which need to be satisfied for a feasible IVHW communication module:

- The **range** of the inter-vehicle communication should be superior to 1km, even under unfavorable conditions (hills, buildings, fog, traffic etc.)
- If possible, **no additional antenna** should be necessary on the vehicle for reasons of integration costs. Both FM and GSM antenna of the vehicle can be used.
- The frequency band and transmitting scheme used have to comply with **regulations** in Germany, France, and other European countries where IVHW is supposed to be installed.

However, some properties of the application are making things easier:

- The **data size** of a digital IVHW message to be transmitted is less than 500 bits.
- The time **delay** for message transmission is not critical and can be up to 1s.

#### 3.1 Communication module using the ISM band (869.4MHz)

Both legal and technical reasons justify the ISM (Industrial-Scientific-Medical) band at 869.4MHz and a FSK modulation for the digital transmission of a specified protocol. As it can be seen in the ERC 70-03 band plan for short range devices, the band at 869.4 – 869.65MHz is the only license free band allowing a transmission power of up to 500mW. The 250kHz wide band is divided into 10 channels of 25kHz bandwidth. Only for certain circumstances (transmission of high data rates) it is possible to use the complete band for one application. Since the frequency band is close to GSM (900MHz), the directional characteristics of the mobile phone antenna are favorable for this frequency.



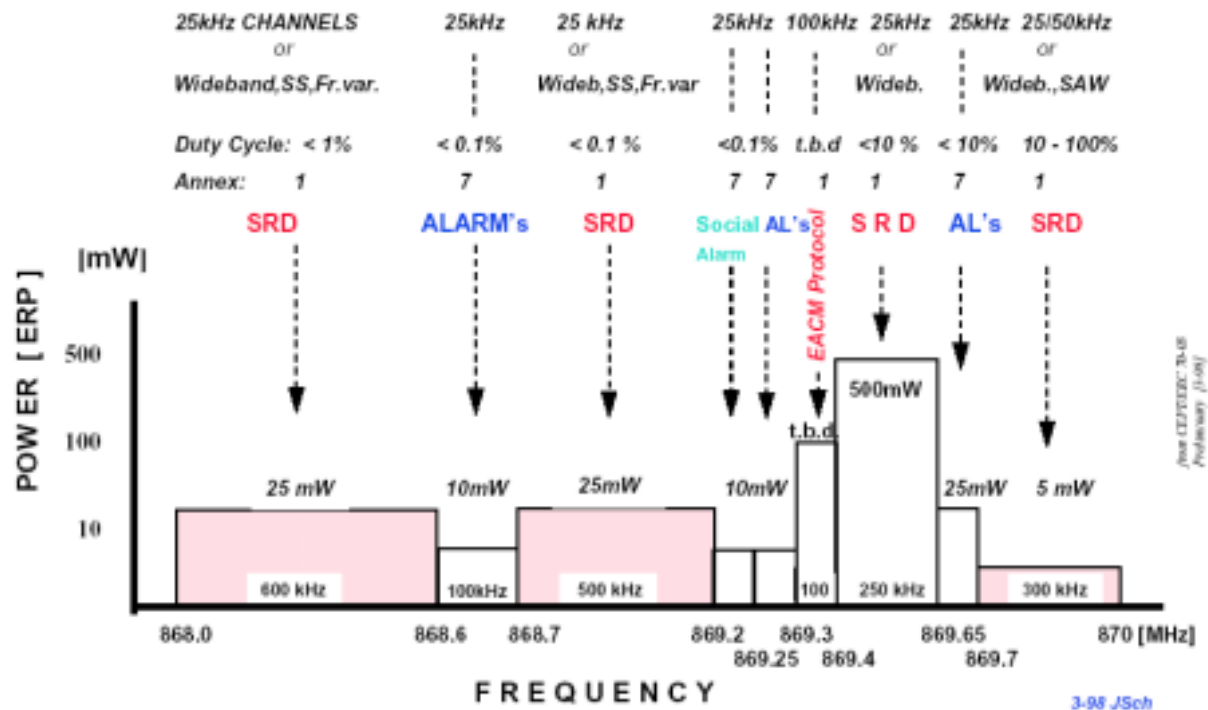

Figure 4 : ERC 70-03 band plan for short range devices at 868MHz (Source: Motorola)

### 3.1.1 Difficulties with the ISM band

Since the IVHW communication module needs to be designed as low cost device, three major difficulties can be identified which are connected to the choice of the ISM frequency band at 869.4MHz :

- The regulations concerning the 25kHz channels are very restrictive. In order to protect adjacent channels, the transmitter needs to have a precise clock reference. Assuming a maximum tolerance of 1kHz, the required precision can be calculated as follows:

$$\frac{\Delta f}{f} = \frac{1 \cdot 10^3 \text{ Hz}}{870 \cdot 10^6 \text{ Hz}} = 1.15 \cdot 10^{-6} \approx 1\text{ppm}$$

Devices with this precision require a temperature compensation or a thermostat and are very expensive. In any case, being forced to use one narrow 25kHz channel would boost the costs for the communication device by at least 100€.

However, using the whole 250kHz wide band would not only increase the data rate but also permit less precise RF components.

- Sharing the GSM antenna of the mobile phone with the IVHW communication module is not a trivial task. The transmitting power of the car phone amounts to 38dBm, while the sensitivity of the IVHW receiver should be -105dBm. Both functions, GSM transmission and IVHW reception, have to work simultaneously. The IVHW receiver has to be protected by at least three filters at different frequency stages in order to guarantee hazard signal reception while the GSM phone is used. Vice versa, an additional RF device has to protect the GSM receiver while the IVHW module is transmitting. The required components are filters and splitters with high requirements, which may cause

additional costs of 20-30€ for the IVHW communication module. Additionally, the GSM application can slightly be degraded concerning both transmitting power and sensitivity.

- In general, building radio devices at frequencies approaching 1GHz is not a low cost solution. Low noise amplifiers and power amplifiers for these frequencies together with filters and transceiver devices are currently not available below 20€, even for quantities above 100k.

Field trials with an ISM communication module revealed problems concerning the communication channel. As long as there was intervisibility between transmitting and receiving vehicle, the range of the communication was very good (up to 5km). However, with obstacles in the communication path like buildings or hills, the communication was usually interrupted due to the short wave length at 870MHz.

Additionally, strong channel fading was observed when driving in multipath propagation environments. Fading intervals

$$t_{\text{fading}} = \frac{\lambda}{v} = \frac{0,35\text{m}}{v}$$

depend on vehicle speed (for example 12ms for 80km/h) and are therefore likely to interrupt transmitted warning messages. Appropriate measures need to be taken (channel coding, shorter messages) in order to overcome this problem.

In the worst case, being restricted to a narrow 25kHz channel by the ERC regulations and having to share the GSM antenna with the mobile phone, the costs for the communication module would be unacceptably high. The costs of a design prepared by the project partners at Robert Bosch GmbH obeying the restrictions mentioned above was estimated at 270€.

Assuming a license to use the whole 250kHz band at 869.4 – 869.65MHz, costs for a communication module connected to the GSM antenna would still be around 50€ (all cost estimations for economies of scale).

## 3.1.2 Realizations for ISM communication modules

There is a variety of RF transceiver chips from different manufacturers which can be used for an ISM module at 869.4MHz. Potential candidates are:

- TRF690x (Texas Instruments)
- AT86RF211 (ATMEL)
- CC1010 (ChipCon)
- nRF903 (Nordic)

All of these devices are able to convert a digital data stream into a transmittable HF signal and vice versa. The price for these transceivers varies between 3-4€ per item for charges of 100.000 or more. Modulation schemes and encoding techniques vary slightly among the devices. However, costs for additional circuitry like microcontrollers, amplifiers and filters may differ significantly depending on the system specification.

In general, it is not possible to add filters at intermediate frequencies in order to reject GSM signals in the receiver. This is due to the integrated design of the devices. Therefore, connecting communication modules based on one chip transceivers to the GSM antenna is very difficult, since the strong GSM signals have to be filtered at the RF stage already. The

relatively cheap one chip solutions (around 30€) have therefore been tested with a separate antenna so far.

The communication module can be decomposed into four components:

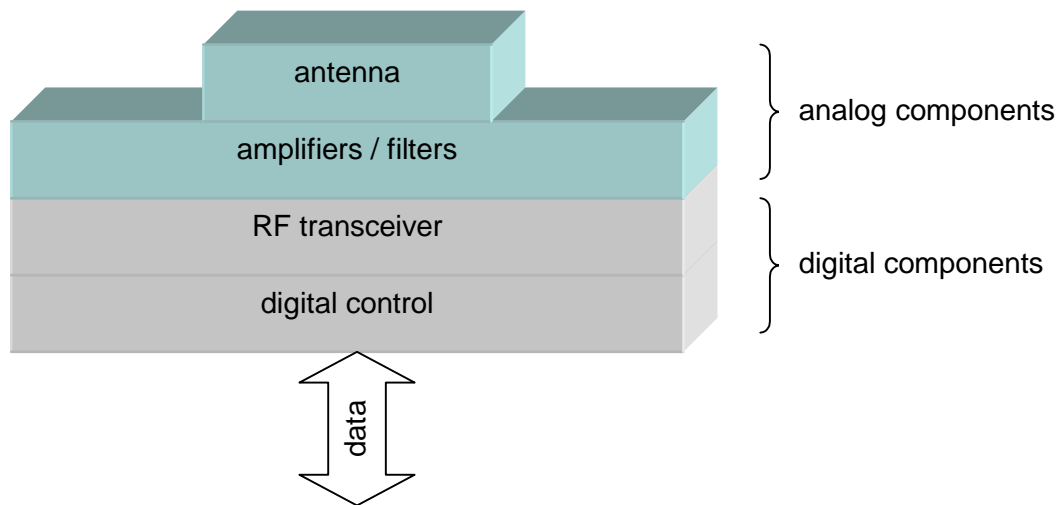

**Figure 5 : Layout of a communication module with single chip transceiver device**

### 3.2 Communication module using FM (87.340 – 87.415MHz)

The technical and cost related difficulties of the ISM band could be avoided by a communication module using frequencies just below the FM radio band (also known as Eurosignal). Unfortunately, the regulations in Europe are different concerning this frequency band. In Germany, the frequencies are reserved for FM radio operators. However, it might be worth to look for possibilities to use frequencies between 70MHz and 87.5MHz for IVHW, since the benefits for the communication module would be significant.

Looking at costs for an FM communication module and comparing it to the difficulties with ISM, the following statements can be made:

- Components for frequencies below 100MHz are much cheaper than for 1GHz. Oscillators with a precision of 10ppm are sufficient. Off-the-shelf components can be used as power amplifiers and low noise amplifiers.
- Sharing the FM antenna instead of the GSM antenna is much easier and cheaper. The only measure to be taken is to protect the FM radio receiver from the IVHW signals.

A rough design for an FM transceiver does not show the need of any expensive components. For the receiver part, integrated Japanese FM radio devices for might be used (FM radio in Japan till 76MHz). The propagation properties for FM frequencies are very favorable for the demands of IVHW, since obstacles or reduced intervisibility between transmitter and receiver are less crucial for larger wave lengths. With an appropriate design, the costs for an IVHW communication module could be below 10€.

### 3.3 Summary on technical options

The following diagram shows the described options for the IVHW communication module, according to frequency band and antenna. The estimated costs have been determined by calculating the lists of materials for the corresponding designs. These costs are subject to change whenever new radio devices become available or new designs are required. They should serve as rough estimates for the impact of the choice of a certain frequency band / antenna layout.

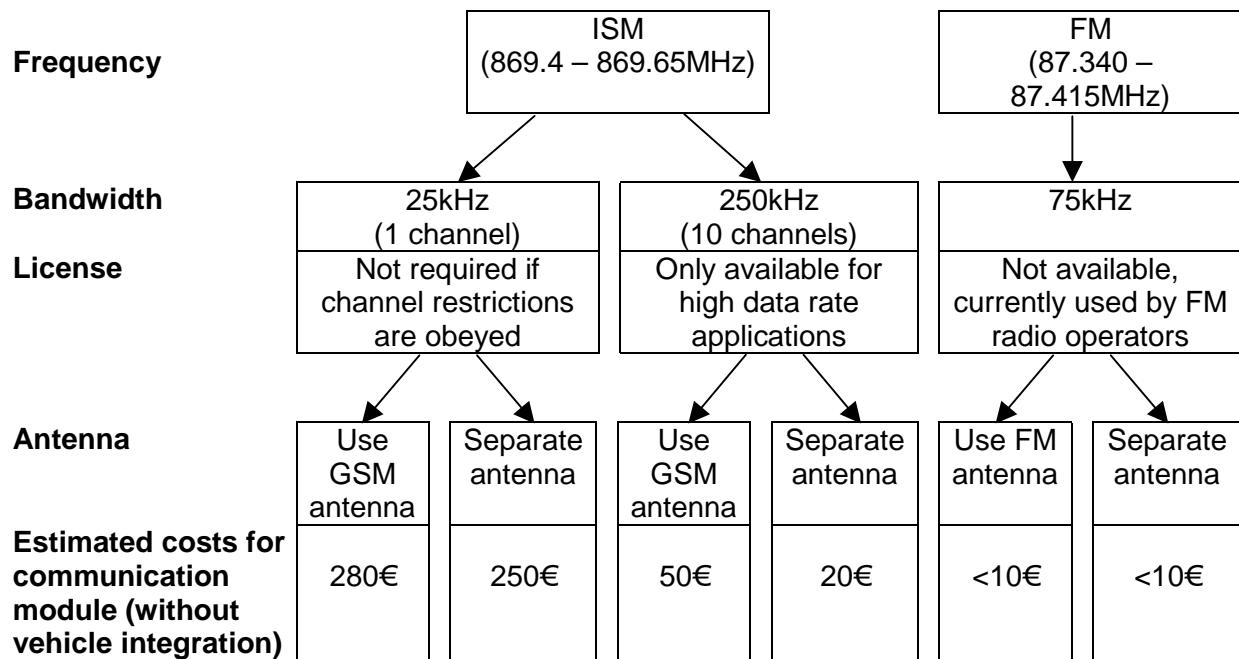

**Figure 6 : cost estimations for various communication modules (costs per unit for charges of 100 000)**

## 4 Standardization issues for IVHW realization

### 4.1 Why is standardization necessary?

In order to make IVHW effective in the European road traffic a significant number of vehicles need to be equipped with the respective device. Therefore, a key prerequisite for further progress is an agreement of European car manufacturers on the functionality of those IVHW system elements which are crucial for the interoperability of the IVHW devices of all vehicles independently of the respective brand.

No one of the European car manufacturers is able to realize the IVHW system single-handedly. It is common interest to establish a standard for IVHW.

### 4.2 Prototype for demonstration

During the first year of the project the partners agreed on a common system concept. The results of this work were shown at the ITS e-safety congress in Lyon in September 2002. The demonstration included three vehicles and a truck as well as fixed beacons. This presentation showed that the idea of hazard warning by direct vehicle to vehicle communication is basically working and further steps towards putting IVHW on the market can be taken.

### 4.3 Steps towards a consensus

The IVHW consortium has approached the EUCAR (European Council for Automotive R&D) working group "Advanced Control & Vehicle Information" (SGA) to share the idea of IVHW and invite their comments on the system concept and to achieve a consensus on crucial specifications.

A description of the IVHW system concept and first draft specifications for the IVHW message content as well as for the characteristics of the radio communication systems have been presented to SGA in September 2002 [6]. SGA has officially been asked for support by the DEUFRAKO consortium.

In November 2002, the IVHW concept was discussed within SGA and received positive feedback. The Inter-Vehicle Hazard Warning system concept as described in [6] is substantially accepted by all European OEMs. However, for a full formal acceptance, the IVHW systems specification needs to be complemented by a complete list of possible hazard types and unified icons/graphics for hazard type presentation in the vehicle. In order to achieve this despite the completion of the DEUFRAKO IVHW project by the end of 2002 IVHW will become a working item on the SGA .

It was agreed amongst the SGA representatives that an industrial consensus is favored at this point in time over formal standardization efforts. The main argument for this favored approach is that IVHW as a product can be pushed faster into the market, and therefore, required penetration rates can be achieved earlier with less effort. Formal standardization efforts should only be started when required.

The SGA members see a need for standardization of the visual symbols for the different hazard types, similar to the warning flasher sign.

## 5 Market Penetration Scenarios

The functionality of the IVHW concept requires a certain concentration of equipped vehicles. As shown in a previous project (MoTiV), a percentage of 15% of all vehicles is desirable for IVHW. In essence, this can be reduced to the key question.

*“Which penetration rate of IVHW systems in motorway traffic can be achieved within five years from market introduction if implementation is based on navigation systems ?”*

Penetration rates for Germany and France have been computed based on total number of cars and new car sales, car usage patterns on motorways and availability of terminal units (OEM navigation systems and after market). These penetration rates can then be used to evaluate different introduction scenarios with respect to system benefit.

Relevant factors for the estimation of the penetration rate for the total fleet are the total number of cars and the new car sales for different vehicle segments. The table gives the classification used by DRI market research [10] and some examples of cars for each category. The segments C, D and E are subdivided in a lower and an upper end.

Vehicle Segment	Examples
A: Utility	Citroën C2, Ford Ka, Renault Twingo, Smart, VW Lupo
B: Supermini	Citroën Saxo, VW Polo, Peugeot 206, Renault Clio
C1: Lower Medium	Mercedes-Benz A, Audi A2, Peugeot 306, Renault Mégane, VW Golf
C2: Medium	Audi A3, Toyota Prius, VW Bora
D1: Upper Medium	Citroën Xantia, Peugeot 406, Renault Laguna, VW Passat
D2: Executive	Audi A4, Mercedes-Benz C, BMW 3
E1: Large & Luxury	Chrysler 300M, Mercedes-Benz E, Peugeot 607, BMW 5
E2: High Luxury	Audi A8, BMW 7, Mercedes-Benz S
Others	Subdivided in Car Derived Van, Micro Van, Medium Van, Multi Purpose Vehicle, Sports Utility Vehicle

The classification scheme is designed to identify sets of products which consumers recognize as falling within competing categories. The segmentation is therefore hybrid in vehicle size and price / market position. This can be seen from the classification of for example of a Renault Laguna in D1 and Audi A4 in D2 even though the vehicles are comparable in size.

For the expected penetration of the platforms considered on motorways, the composition of motorway traffic has to be taken into account. Data available comprises the total mileage and the mileage on motorways for different vehicle segments. The distribution of motorway traffic is a complex issue and differs significantly with respect to working days and weekends, season, and region. All these criteria need to be taken into account separately, but there is no systematic data available.

Based on these findings, a configurable computation of the percentage of IVHW-equipped vehicles in motorway traffic has been implemented. Figures from this computation are given for Germany and France. For France, some assumptions based on little data (concerning motorway traffic and navigation system market) had to be made. These results have to be considered with great care, as the situation is quite different for France than for Germany. For more conclusive results, additional information is needed.

## 5.1 Germany

### 5.1.1 Car market

The assumptions made on the future development of the German car market are illustrated in Figure 7.

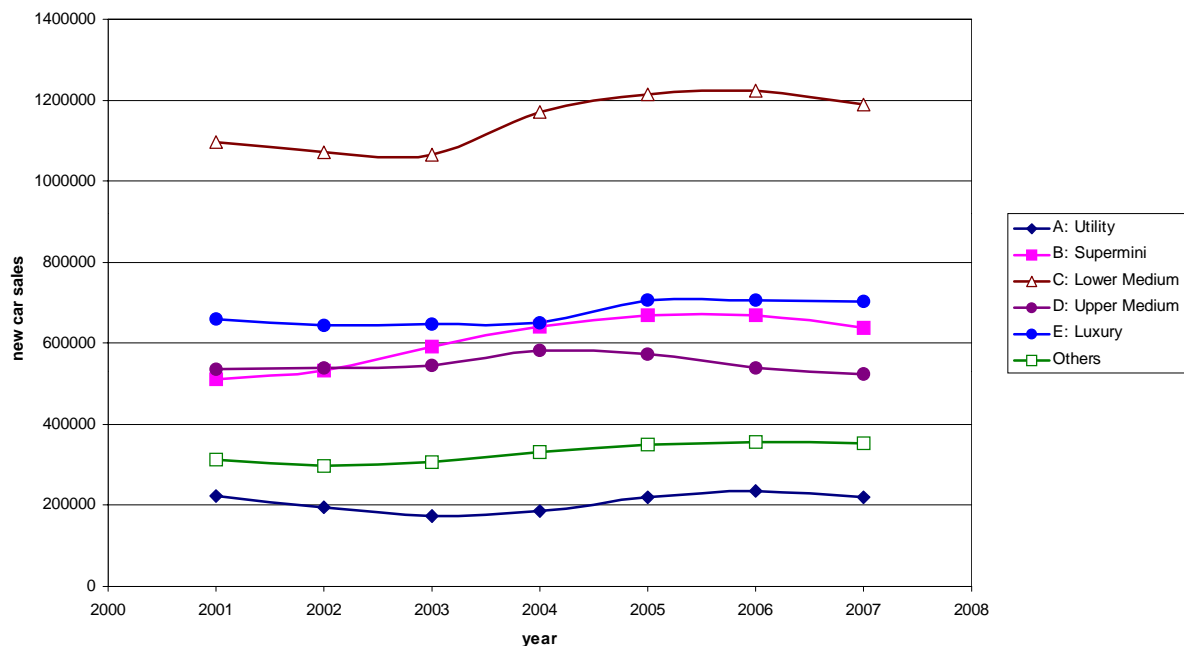

**Figure 7 : new car sales by vehicle segments for Germany [9]**

The total number of new car sales is slowly rising until 2005 and crossing 3,7 million over the period considered. After 2005, there is a general downward trend for sales of all car segments. There are only moderate shifts in the expected distribution of the vehicle segments. The Supermini segment is rising while the lower medium segment is decreasing until 2003. After 2003, the lower medium segment and 'others' (vans, pick-ups, SUV's) are expected to gain market share. Upper Medium and Executive (D+E) segment are more or less constant. Sales of Upper Medium and Executive segment represent one third of total sales in Germany.

The total car park in Germany is increasing from 44,1 million cars in 2002 to 45,2 million in 2006. The composition of the total car park concerning vehicle segments is converging towards the composition of the latest new car sales, even though older models can not always be placed in the segmentation table above.

With about 3,5 million cars being shut down or sold outside Germany every year, the average life cycle of a car is 12,9 years. This value is usually lower for higher car segments and especially for company cars with a high mileage.



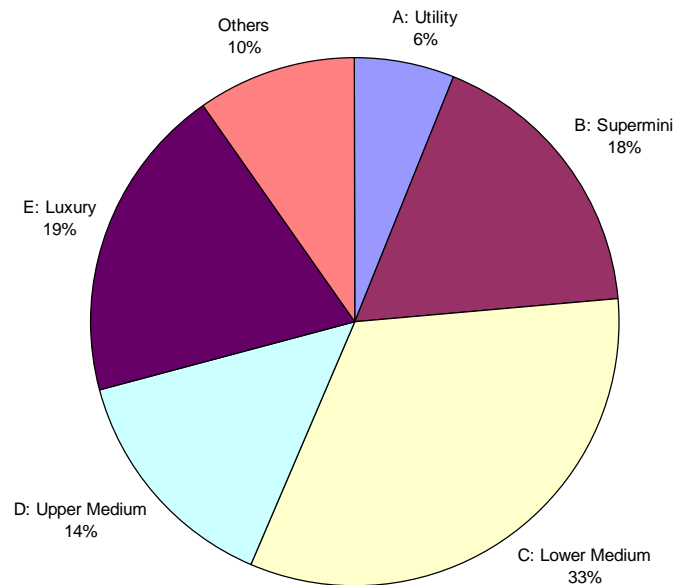

**Figure 8 : segmentation of new car sales in Germany, forecast 2007 [9]**

The upper medium and luxury segments are playing a particularly important role in Germany with a market share of one third. The lower medium segment has the highest percentage with one third as well, while the last third is shared between utility and supermini segment, together with other vehicles. The utility and supermini segment is very small compared to other European countries.

### 5.1.2 Car usage pattern

The number of kilometers driven on motorways varies significantly over the car segments. The car usage pattern is therefore important for the estimation of the penetration of IVHW-equipped vehicles on motorways.

Total mileage for Germany reached 600 billion km per year in 1998 and is currently increasing with a rate of 1 – 2% per year. The percentage of mileage on motorways reached 31% in 1998 and is increasing by 0.5 percent per year. Increase is mostly due to the still growing heavy goods traffic on motorways.

The distribution of traffic according to weekdays and holidays can be characterized as follows. The total number of trucks does not vary significantly with the exception of Sundays and public holidays when they may use motorways with a special permit only. Flow of passenger cars is highest during holidays and lowest on Sundays. Traffic flow for work days is approximately the total average. There is probably also a different distribution of vehicle segments for work days and holidays, but there is no data available.

The total mileage per year for passenger cars is decreasing in long term trend for Germany. This is due to the increasing number of second and third cars. Currently, it is about 12700 km per year. Data on mileage is available for used car sales only. The figures provided may actually give a higher mileage as the total mileage, because the cars sold might be used more. Figures are usually provided for cars aged 1 to 5 years and not older.



Mini	14000 km / year
Medium	17705 km / year
Luxury	21700 km / year

**(Source: Eurotax Schwacke, List of Used Cars 1997)**

In any case, the mileage of segment D+E cars is significantly above average, which justifies the assumption of a higher percentage of these cars on motorways than it might be deduced just from the sales figures. The corresponding factor is very hard to determine, since it varies strongly with time (day, week, season) and region (especially east / west). Different counts on German motorways have shown results with a huge variance, so it was impossible to quantify the effect of the car usage pattern in a reliable way. In general, the interesting market segments D+E for navigation systems and IVHW have a stronger representation on the motorways than in the sales statistics, with counts varying between 35% and 60% of total cars on motorways.

### 5.1.3 Trucks

The number of trucks on German motorways plays a particularly interesting role, since all trucks above 12t are included in the Electronic Toll Collect system (ETC) from 2003 on. Since the system is based on GPS navigation, trucks equipped with ETC are a potential target for IVHW. Additionally, trucks have a high mileage and are mainly used on motorways. During working days, their concentration on German motorways is therefore much higher than their market share concerning sales figures.

In 2000, the total number of trucks was approximately 2,5 million in Germany [11], compared to 43,7 million cars [9], which corresponds to a ratio of about 5,7%. However, exemplary counts on different German motorways revealed a significantly higher percentage of more than 15% during weekdays, also due to foreign trucks (see Appendix).

From the perspective of IVHW, trucks are a challenging segment. Not only is there a particular demand for hazard warning systems due to their long braking distance, but also their strong presence on the motorways and their legally enforced GPS equipment might become key factors for IVHW market extension in the future.

#### 5.1.3.1 Electronic Toll Collection systems

Germany will introduce a distance-based toll for heavy trucks (> 12t) in 2003. Dornier System Consult estimates that there are 500.000 German and 250.000 foreign trucks with a total mileage of 25 billion km per year on motorways affected. This amounts to a proportion of heavy trucks of 15% of total motorway traffic or an average mileage of 33.000 km per year on motorways for trucks [12].

Terminal units include a positioning system with dead reckoning and a GSM communication module. However, the HMI functionality of the Toll Collect devices is not sufficient for IVHW realization yet, so equipping trucks retrospectively is not an option.

#### 5.1.3.2 Fleet management systems

Fleet management systems need a terminal unit in the vehicle usually comprising GPS for positioning and communication devices (GSM, other) for the connection to a service center. Additionally, data from the vehicle can be accessed via a link to the vehicle bus (CAN). A digital road map is not included so autonomous navigation is not possible. Using the position data from GPS, the vehicle can be located on a digital road map in the service center.

The terminal unit offers basic functionality for an IVHW system comparable to those of a toll collection unit. Currently, there are many solution providers offering different hardware and software for fleet management. Considering the compulsory introduction of electronic toll collection, the functionality of the fleet management terminals will probably be integrated within the ETC on-board unit. Therefore, we will not consider solutions based on fleet management systems for the estimation of IVHW penetration rates.

### 5.1.4 Navigation systems

Navigation market started with significant sales volumes from 1990 in Japan. In Japan, more than one third of new cars were equipped with navigation systems (OEM and after market) in 2000. For 2005, the penetration rate is expected to reach more than 50%. In Europe, navigation systems were introduced in the mid-90s. US market is expected to follow within the next few years.

Reliable forecasts for OEM navigation systems are hardly available, so estimations are based on DaimlerChrysler data on equipped vehicles and forecasts from navigation system manufacturers, which are varying significantly.

For the introduction of IVHW, the number of navigation systems sold as OEM with the car is more important than the total number of navigation systems. However, two major navigation system manufacturers in Europe, VDO and Bosch, reported a trend towards more after market integration of navigation systems in 2000:

- VDO: 70% OEM in 2000 decreasing to 58% in 2004
- Bosch: 60% OEM in 2000 decreasing to 50% in 2004

The following diagram gives the expected equipment rate of OEM navigation units sold in Germany. Additionally, the lines above the bars are representing the expected equipment rate of after market navigation systems. Both equipment rate of new cars (red) and equipment rate of the total car park (blue) are illustrated. Figures are based on the assumption of Germany representing about 40% of the European market.

Yet, the distribution of navigation systems is concentrated on higher vehicle segments due to their price.

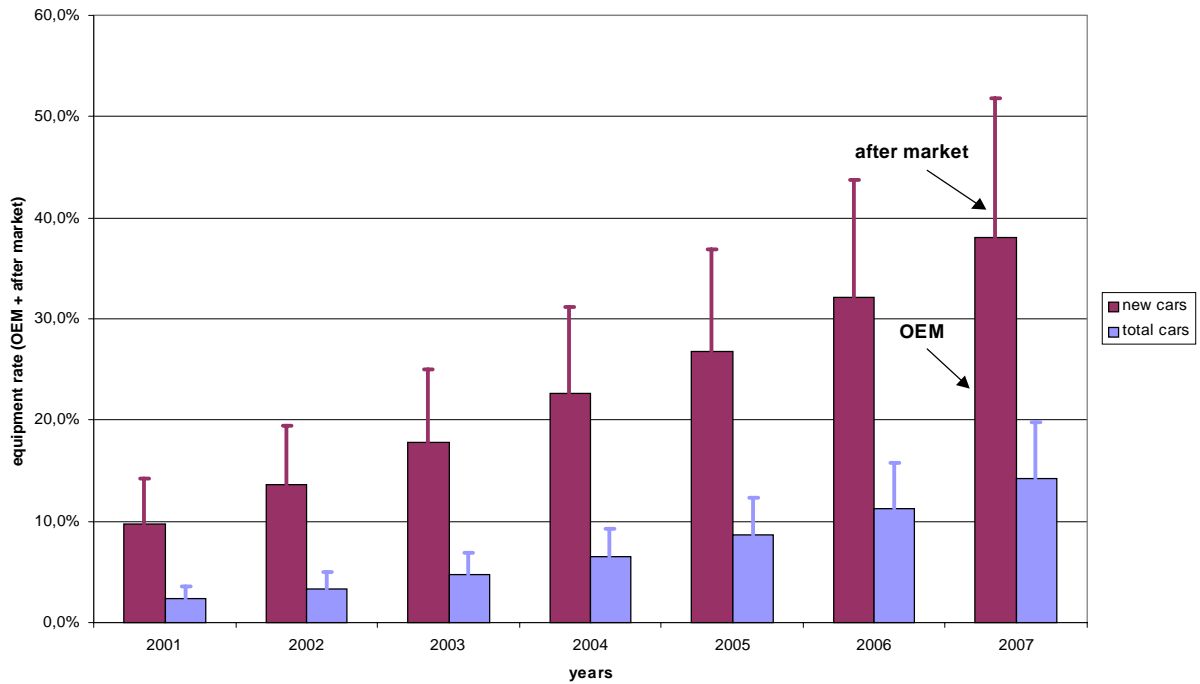

**Figure 9 : equipment rates of navigation systems in Germany (OEM + after market) for new cars and for the total car fleet (Source: Robert Bosch GmbH, 2002)**

OEM equipment rate is expected to rise to 38% for new cars by 2007 (more than 50% if after market systems are taken into account). By this year, cumulated navigation systems will reach 14% of the total car fleet (20% with after market). Figures are based on a total OEM market of 1.000.000 units for Germany in 2005 representing a 40% share of the European market volume of 2,5 million units.

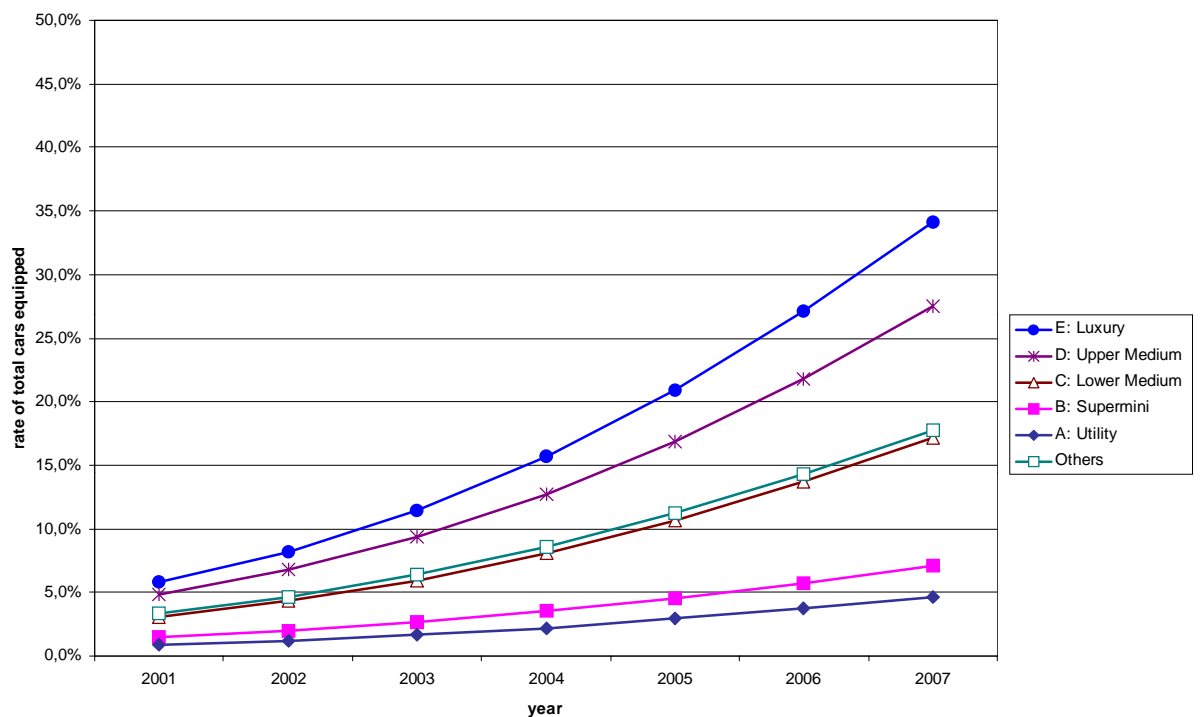

**Figure 10 : ratio of navigation systems in total car fleet for different vehicle segments (estimation)**

### 5.1.5 Penetration rates of IVHW on motorways

Relevant factors for expected penetration rates on German motorways are the distribution of navigation systems and the car usage pattern of the upper medium and luxury segment. The fraction of new cars is higher than average in upper medium and luxury segment. Navigation systems are more common in these segments. Concerning car usage, the total mileage and the percentage of mileage on motorways are significantly higher than average. As stated above, these factors are hard to quantify and several counts showed a high variance of motorway traffic.

For the derivation of potential IVHW penetration rates on motorways, we make the following assumptions:

- the traffic composition on motorways corresponds to a configurable distribution (see Appendix)
- navigation systems are present in different vehicle segments as described in the last chapter
- IVHW implementation in navigation systems is rising constantly from market introduction on and is becoming standard (all navigation systems feature IVHW) after five years

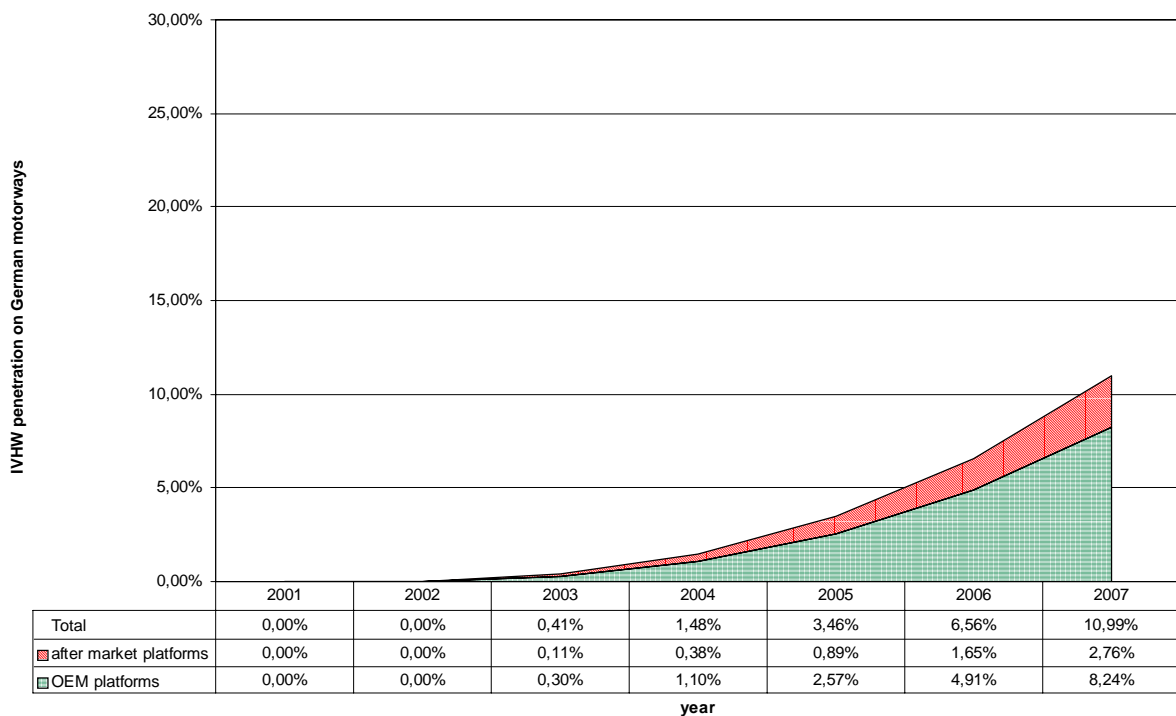

**Figure 11 : penetration rate of IVHW on German motorways within five years from market introduction (estimation)**

With the assumptions above, we can see that OEM systems contribute stronger to the IVHW penetration on motorways. In this scenario, the desired penetration of 15% cannot be reached within five years after market introduction. Including after market navigation systems, the IVHW penetration rate reaches 11% until 2007. It should be noted, however, that trucks are not considered in this scenario (for example during weekends in Germany). Since trucks contribute strongly to motorway traffic on weekdays, IVHW equipped trucks could boost the penetration rate significantly.

It should be stated that these figures can only represent an average motorway situation. Penetration might be lower in Eastern Germany with a lower market share of high vehicle segments, but it might also be higher in other parts of the country during rush hour traffic with a higher concentration of company cars.

A more detailed output of the calculation tool created for the market penetration estimations can be found in the Appendix.

## 5.2 France

### 5.2.1 Car market

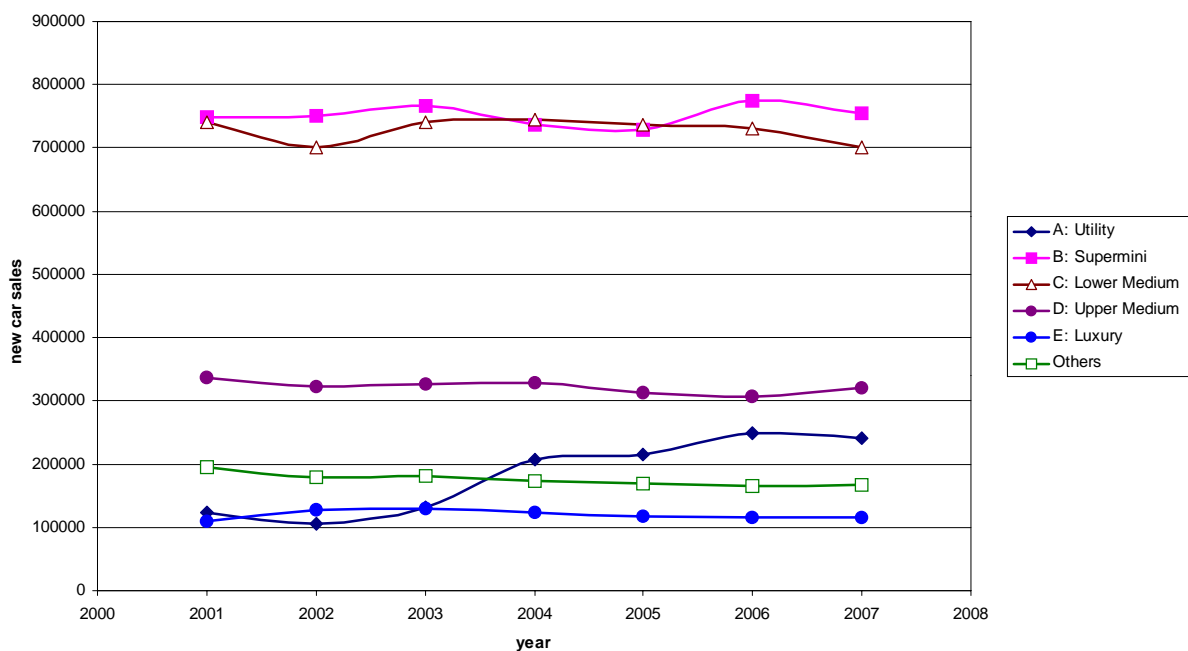

**Figure 12 : new car sales by vehicle segments in France [9]**

The distribution of new car sales by vehicle segments is quite different than for Germany. The Supermini and Lower Medium are the most important segments in France with slightly decreasing tendency. A significant rise is expected for the Utility segment only. The Executive segment is very small. The fraction of the D+E segment is 19% only, compared to 33% in Germany.

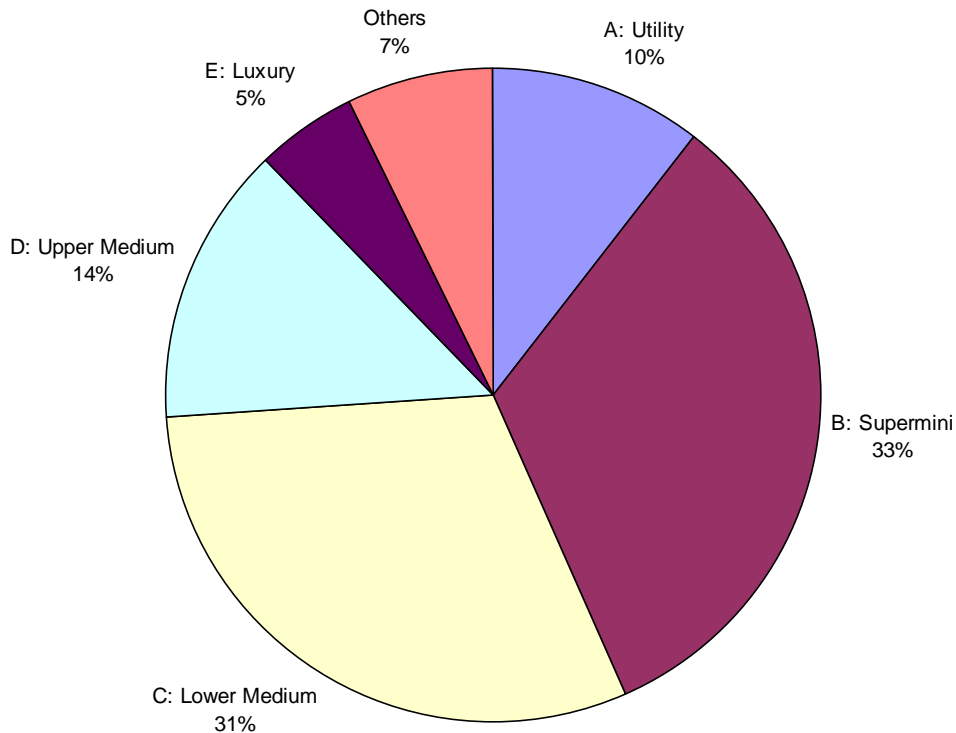

Figure 13 : segmentation of new car sales in France, forecast 2007 [9]

### 5.2.2 Car usage pattern

We assume no major differences to the German car usage pattern concerning mileage in the different vehicle segments and replacement rates.

An important difference concerns the motorway structure in France, being centralized with most highways heading towards Paris. All rural motorways outside 20km from major cities are subject to road tolls. Concentration of rural motorway traffic is usually lower than in Germany and depends largely on the season. Major traffic jams are reported every year around the vacation periods. Heavy traffic concentration is usually present on all motorways in the Paris region (Île de France) during rush hour.

### 5.2.3 Trucks

The toll system in France is based on toll booths on the motorways with relatively high fees for trucks. Unlike the Toll Collect system in Germany, no additional equipment in the vehicles is required. Penetration rates of GPS equipment for trucks in France will therefore be more or less the same like for higher car segments (executive or upper medium). Additionally, the concentration of trucks on the motorways is estimated to be inferior (10%) to the one in Germany (up to 15%) due to the toll system.

### 5.2.4 Navigation systems

With a share of about 10% of the European market, the French market for navigation systems is relatively small. Figures for equipment rates of new vehicles are therefore significantly lower than for Germany.

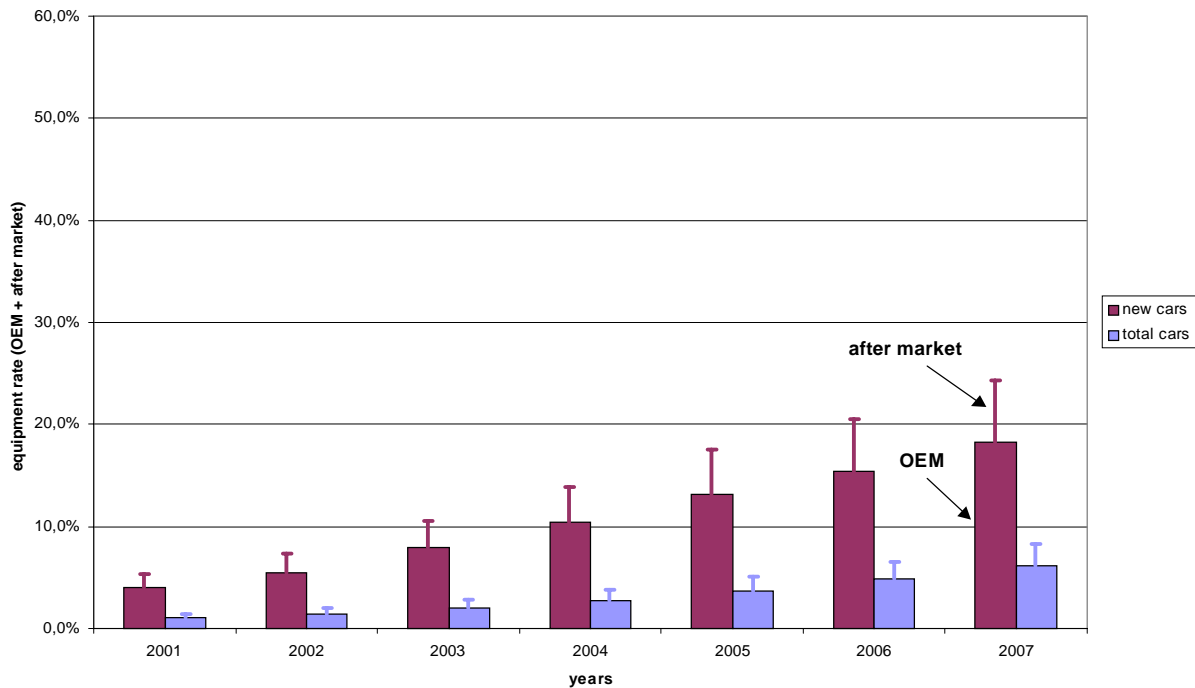

**Figure 14 : equipment rates of navigation systems in France (OEM + after market) for new cars and for the total car fleet (Source: Robert Bosch GmbH, 2002)**

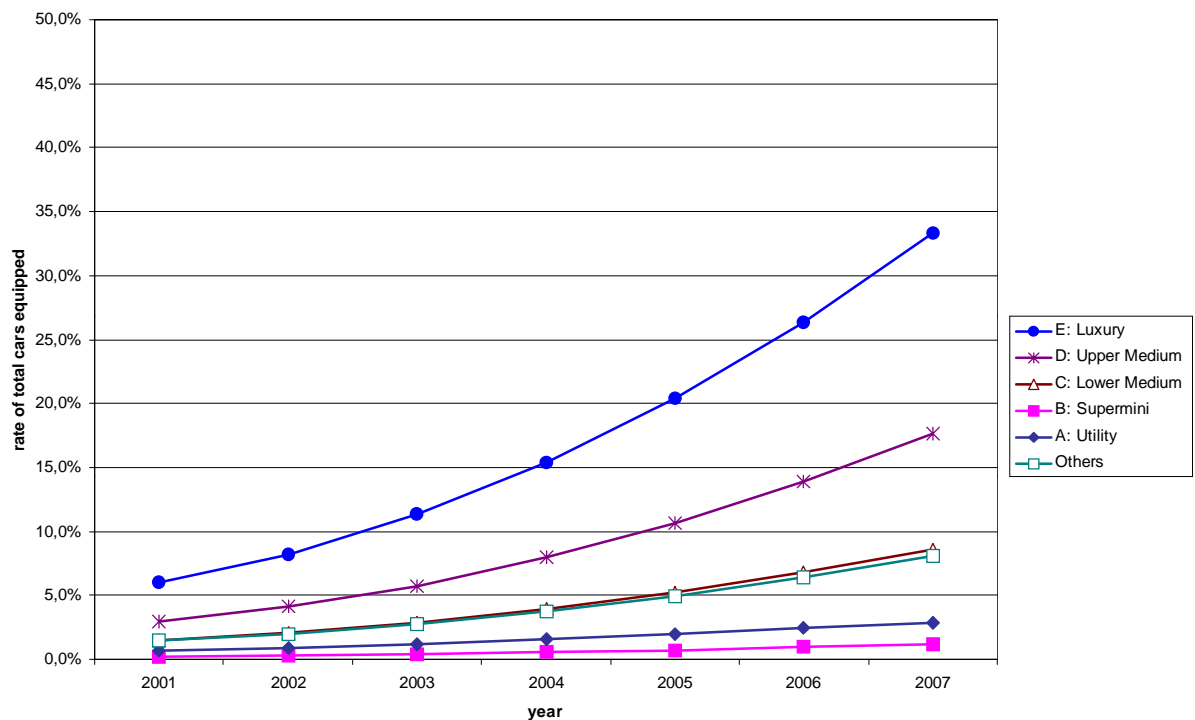

**Figure 15 : ratio of navigation systems in total car fleet for different vehicle segments (estimation)**

The distribution of navigation systems to the different vehicle segments corresponds to the figures in the German forecast, so higher segments also have a higher equipment rate. Growth rates for navigation systems are also assumed to be identical to the German market.

However, since the distribution of vehicle segments is more concentrated on lower segments, overall market size for navigation systems in cars will be lower as well, with a negative impact on potential penetration rates for IVHW.

### 5.2.5 Penetration rates of IVHW on motorways

Following the same approach as for the German penetration rates, the results for France can be obtained by taking the different sales figures for vehicles and navigation systems into account.

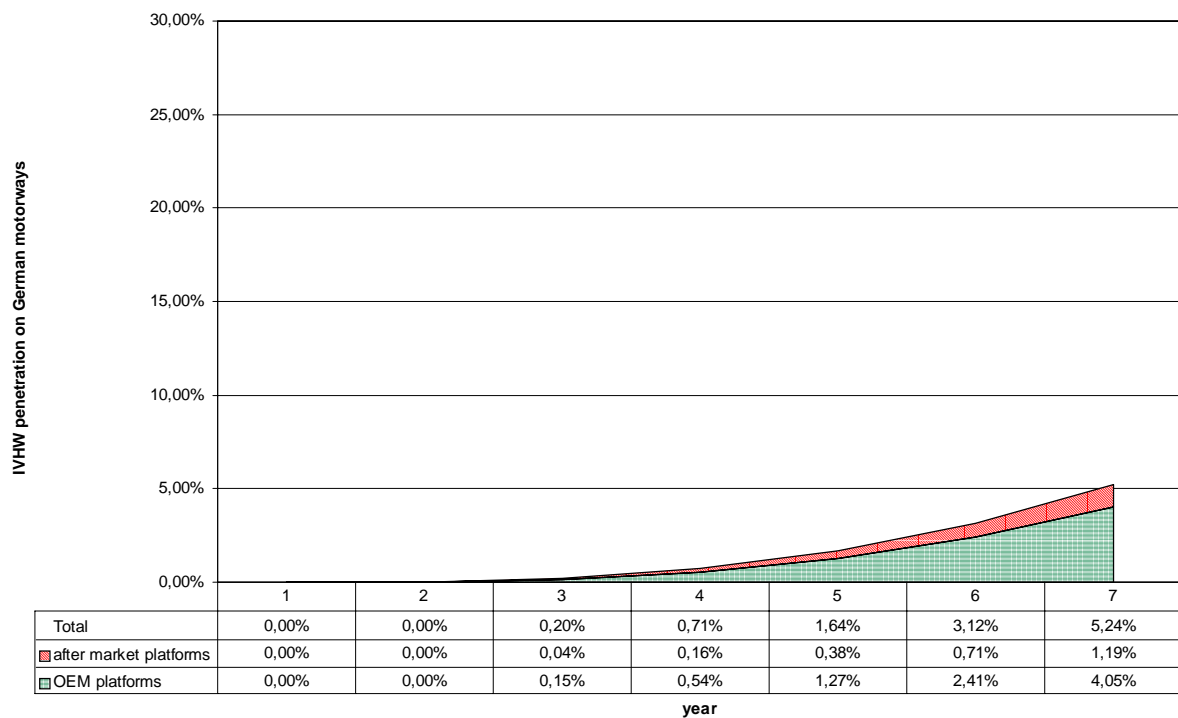

**Figure 16 : penetration rate of IVHW on French motorways within five years from market introduction (estimation)**

The IVHW penetration forecast for France is less optimistic. The low share of upper vehicle segments and the lower equipment rate for navigation systems are the most important reasons for lower penetration rates. According to this scenario, penetration rates only reach 5,2% five years after market introduction, even if after market navigation systems are considered for IVHW implementation.

Again, the detailed outputs of the calculation tool can be examined in the Appendix.



## 6 Market Entry

### 6.1 Market Audit

Summarizing the preceding chapters, the external circumstances concerning IVHW can be characterized as follows:

<p style="text-align: center;"><b>Political</b></p> <ul style="list-style-type: none"> <li>• potential of avoiding 4000 injury producing accidents per year in Germany</li> <li>• public support of research and development to avoid motorway accidents</li> <li>• joint efforts of German and French organizations to realize inter-vehicle warning system</li> <li>• frequency allocation for the communication channel is very restricted</li> </ul>	<p style="text-align: center;"><b>Economic</b></p> <ul style="list-style-type: none"> <li>• costs for warning system are significant (currently at 50€ just for a communication module using the GSM antenna)</li> <li>• additional costs for vehicle integration</li> <li>• rapidly growing market for navigation systems (around 30% per year), reaching one million new OEM units in 2005 in Germany</li> <li>• 8% of all vehicles get replaced every year (3,7 million new vehicles versus total fleet of 44 million in 2002 in Germany)</li> </ul>
<p style="text-align: center;"><b>Social / Cultural</b></p> <ul style="list-style-type: none"> <li>• public awareness of dangerous rear-end collisions on European motorways</li> <li>• navigation systems are still concentrated on upper medium and luxury vehicle segments</li> <li>• different composition of car fleet in European countries (e.g. less luxury cars in France than in Germany)</li> <li>• safety benefit for the general public rather than for the individual</li> </ul>	<p style="text-align: center;"><b>Technological</b></p> <ul style="list-style-type: none"> <li>• IVHW concept requires navigation system or at least GPS equipment in the vehicle</li> <li>• IVHW could be integrated in a new generation of navigation systems or infotainment units</li> <li>• vehicle integration requires access to warning flashers, airbag, and antenna (GSM or FM)</li> <li>• different frequency bands have to be considered for the inter-vehicle communication channel</li> <li>• standardization of communication technology and message content necessary</li> </ul>
<p style="text-align: center;"><b>Market</b></p> <ul style="list-style-type: none"> <li>• IVHW = new product, no market penetration yet</li> <li>• high market penetration required to ensure full safety benefit (10-15%)</li> <li>• total addressable market = new vehicles with OEM navigation system + after sales market for navigation systems</li> <li>• in Germany: growing from 830.000 potential customers in 2003 to 1.370.000 in 2005</li> </ul>	<p style="text-align: center;"><b>Competition</b></p> <ul style="list-style-type: none"> <li>• no direct competition with existing safety systems (Distronic, ESP, ABS)</li> <li>• IVHW concept requires cooperation between vehicle manufacturers to achieve high market penetration</li> </ul>

Figure 17 : PEST analysis of factors relevant for IVHW

### 6.2 Customer perspective

Customers are primarily interested in a products benefits rather than its features, functionality, or political background. A SWOT analysis of the IVHW concept identifies the critical factors that will drive success or failure of the market introduction.

<p style="text-align: center;"><b>Strengths</b></p> <ul style="list-style-type: none"> <li>• reduces my own risk of rear-end collisions and heavy accidents on motorways</li> <li>• creates a safety benefit both for me and the general public</li> <li>• enables me to warn others and therefore creates appreciation</li> </ul>	<p style="text-align: center;"><b>Opportunities</b></p> <ul style="list-style-type: none"> <li>• fast growing market for navigation systems</li> <li>• might become standard functionality of navigation systems and infotainment units</li> <li>• improves reputation of the whole brand</li> </ul>
<p style="text-align: center;"><b>Weaknesses</b></p> <ul style="list-style-type: none"> <li>• requires high market penetration before creating a benefit in safety for me</li> <li>• is not included in the first generation of Electronic Toll Collect systems for trucks</li> </ul>	<p style="text-align: center;"><b>Threats</b></p> <ul style="list-style-type: none"> <li>• critical mass for IVHW might not be achieved</li> <li>• license for frequency band might be subject to change</li> </ul>

**Figure 18 : SWOT analysis of IVHW**

From a customer point of view, the introduction phase of IVHW is particularly crucial. The functionality and the safety benefit of IVHW is basically proportional to the market penetration. Those customers purchasing an IVHW system first are therefore offered the least benefit and have to take the highest risk of investing in a stagnating system.

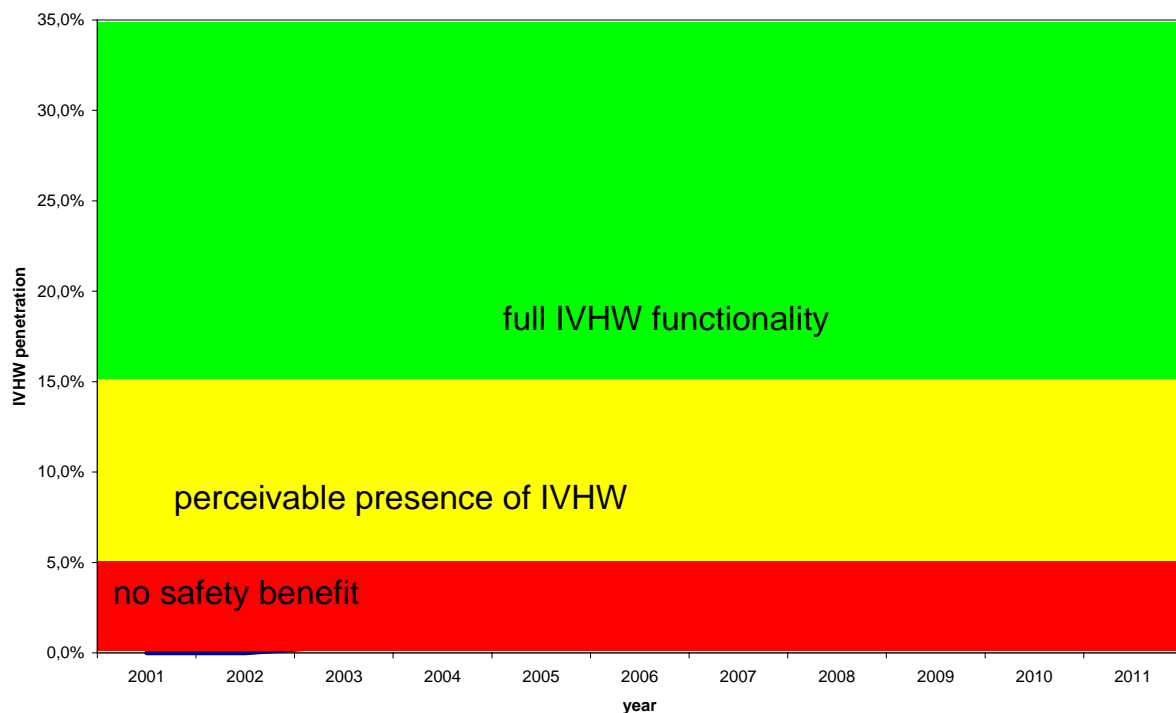

**Figure 19 : three phases of IVHW market penetration**

The market penetration of IVHW is likely to pass through three phases:

- I. introduction (low penetration, slow growth), no safety benefit for the customer
- II. transition (high growth), perceivable presence of IVHW in the traffic
- III. saturation (installed base), full functionality of IVHW

The transitions between these phases are blurred, so the limits are actually not as sharp as shown in the diagram. The lower the market penetration, the higher is also the risk for the customer of IVHW to lose the benefits of the product due to unexpected market behavior. In order to provide a sales argument for the customer, a certain degree of IVHW infrastructure has to be established before making him pay.

### 6.3 Manufacturer perspective

The introduction of IVHW is a typical example of a network externality. Positive network externalities occur if the value of a product increases with its market penetration, e.g. telephones or technical standards (format of video cassettes, CDs, etc.). The mechanism of this positive feedback is the attraction of new customers by the network, which gains in value due to the increasing number of users.

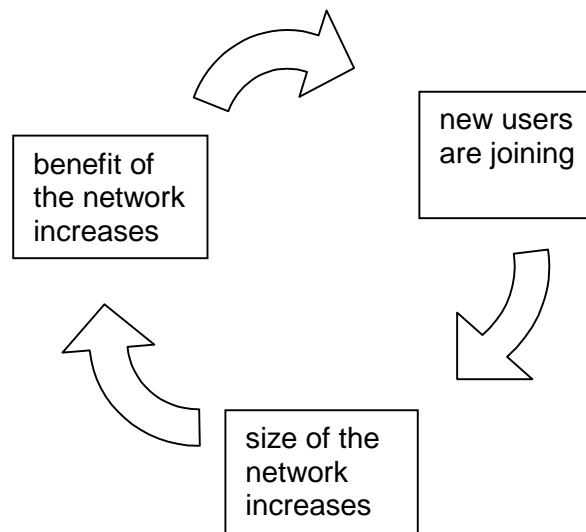

**Figure 20 : positive feedback of network externalities**

There is a number of interesting properties of network externalities:

1. **Critical mass:** once the critical mass of a network is achieved (in the case of IVHW a market penetration of 10-15%), the corresponding product reaches the market saturation phase very quickly due to the positive feedback.
2. **Indirect network effects:** with an established network above the critical mass, indirect network effects can also be taken advantage of, for example using the established inter-vehicle communication for other applications desired by the customer.
3. **Lock-in:** once the system architecture has been defined, the manufacturer is bound to the corresponding standard. Costs for a change of architecture after the critical mass has been achieved are extremely high.

According to the analysis of the IVHW concept and the potential market penetration, the business objective of the market introduction process can be clearly identified:

*“To achieve a critical mass of IVHW on motorways after 5 years.”*

Since the navigation system is the basic part of IVHW, the corresponding business model assumes a supply of navigation systems and communication modules to the vehicle manufacturer, who integrates the components in the car and provides it to the customer by using the conventional distribution channels.

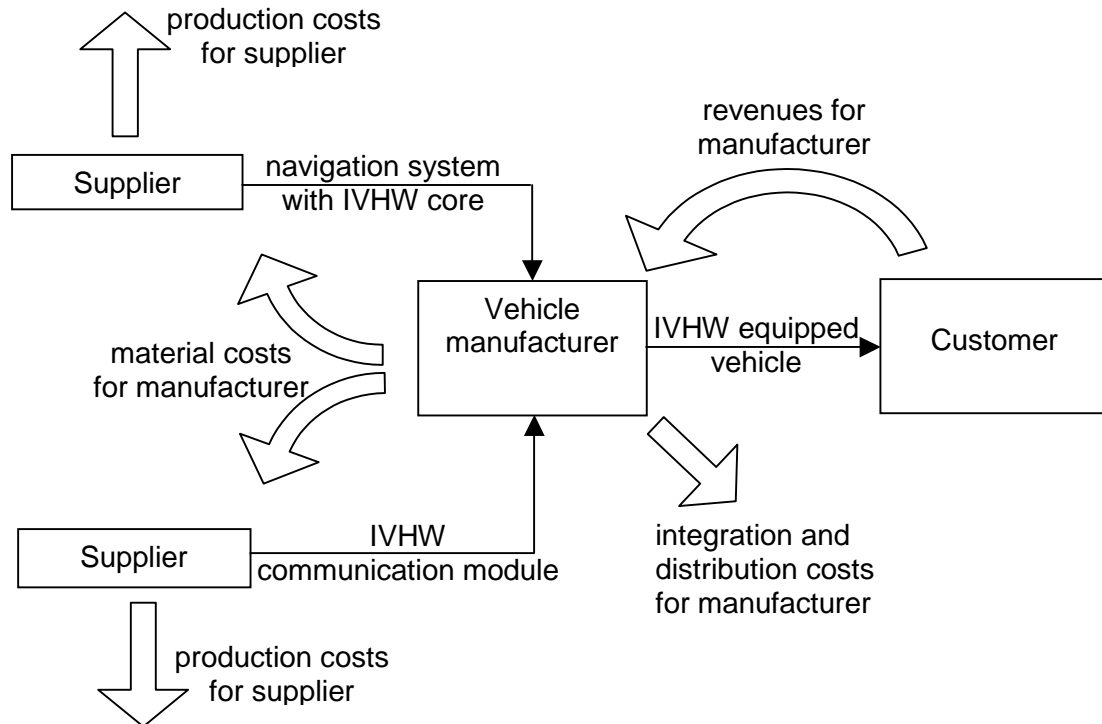

**Figure 21 : business model for IVHW**

The following factors are driving the introduction costs for the manufacturer:

- fixed costs for development of IVHW components
- variable costs for IVHW hardware
- variable costs for vehicle integration

On the revenue side, there are:

- revenues from customers
- public support (tax reductions, bonuses, etc.)

Having identified manufacturer costs and revenues, the total number of IVHW systems necessary to achieve a critical mass has to be considered for a further analysis. In the estimation of market penetration rates for German motorways, the penetration rate exceeds the 10% mark 5 years after market introduction. Looking at the corresponding number of vehicles which have to be equipped with IVHW per year, we get the following diagram (showing the results for Germany and France together). The estimations are results of the calculation tool for the IVHW penetration rates (see Appendix). They are based on the total number of navigation systems sold and an increase of IVHW implementation by 20% every year, starting at 20% in 2003. It is therefore assumed that in 2007 every navigation system (OEM and after market) has IVHW functionality.

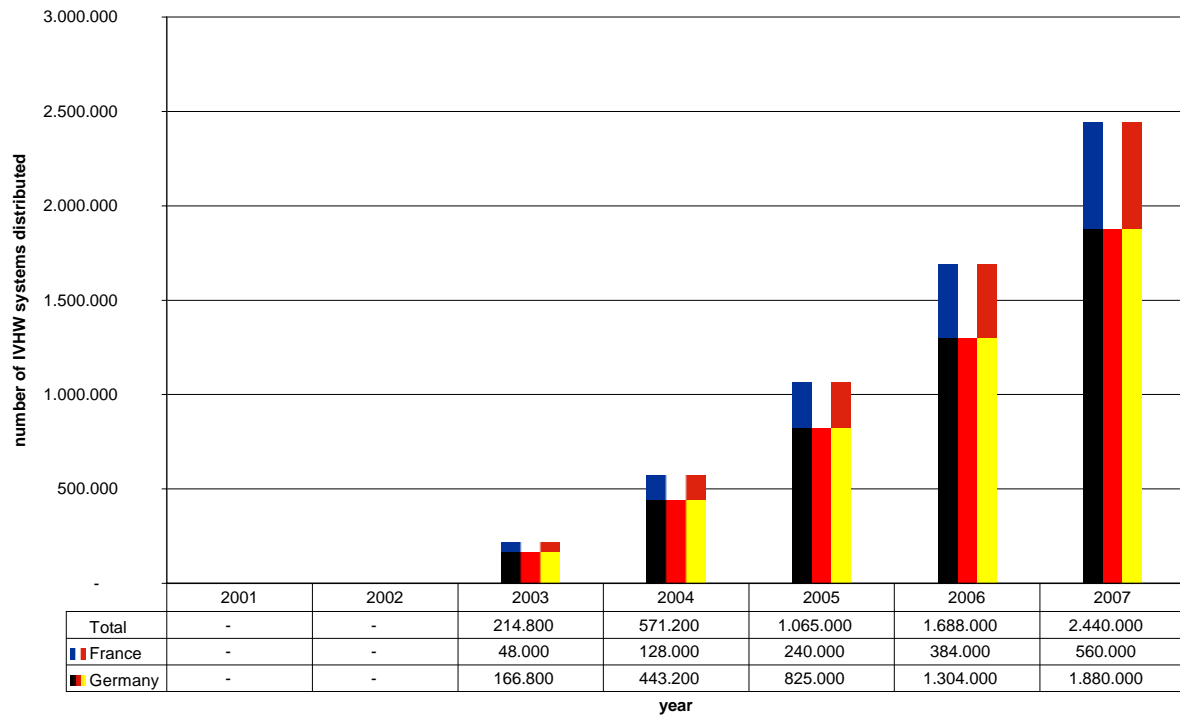

**Figure 22 : estimation of IVHW systems distributed per year in Germany and France**

The cumulated number of IVHW systems distributed in Germany during five years amounts to 4,6 million, which is roughly 10% of the total German car park. For France, the cumulated number is 1,36 million, which is only 4,4% of the total French car park, so a critical mass is not achieved in this case.

As illustrated in the next figure, production costs per unit are decreasing with the sales volume. For IVHW, scale effects reduce the production costs by about 30% every time the number of units is increased by a factor of 10.

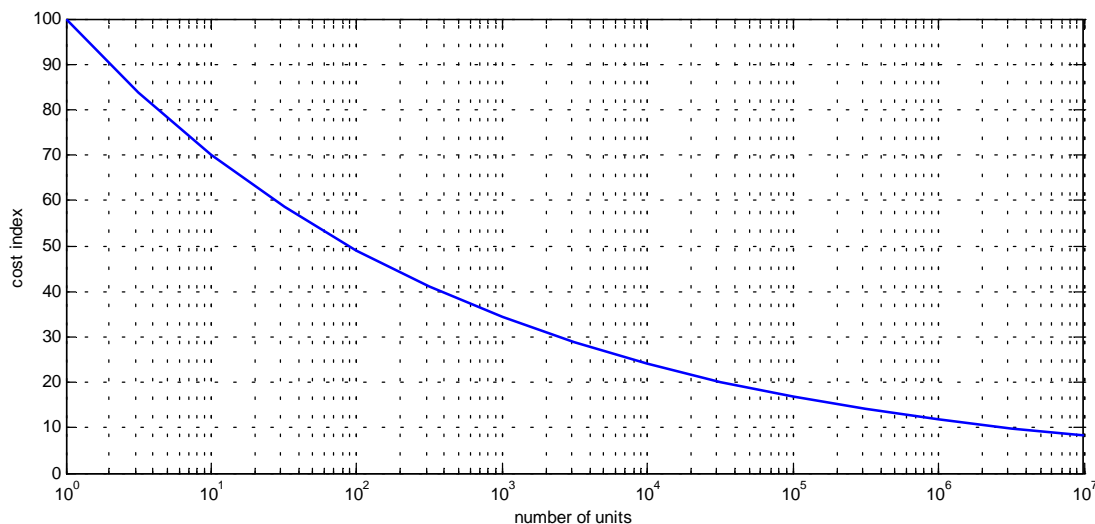

**Figure 23 : cost index of IVHW versus number of units**

### 6.3.1 Market Entry Scenarios

In the following, considerations are limited to the German market, since the initial situation is more favorable than in France due to a higher percentage of navigation systems and upper vehicle segments. More or less favorable scenarios for the introduction phase of IVHW are conceivable. However, one constant remains for every market entry strategy: **4,6 million IVHW systems** have to be installed in Germany before there is a noteworthy customer demand due to network effects.

Each scenario covers a timeframe of the next ten years and aims at determining costs and revenues related to the introduction of IVHW. As a result, the cash flow for every year is computed. According to a specific interest rate, the **cumulated discounted cash flow** is calculated as a measure of total costs / revenues for the corresponding scenario in terms of today's value. Starting with a first approach to market entry ("all expectations met") with the current knowledge base, a **sensitivity analysis** is carried out by varying the level of customer acceptance, system costs, and the role of public funding, in order to observe the impact of these variances on the overall result.

For every scenario considered, a different market entry strategy and different technical concepts are taken into account. The market entry strategy is basically reflected by the **price** of IVHW for the customer. The price is variable with the time, so for example it is possible to offer the system free of charge during the first few years and to sell the system for a higher price later. Another parameter related to the market entry strategy are the **distribution costs** for IVHW, representing additional costs for after market equipment as well as marketing and advertising.

The technical concept is driving the **hardware costs** (e.g. communication module) and the **costs for vehicle integration** (e.g. connections to the antenna, warning flashers, and airbags). Since different concepts are conceivable and the final decisions for frequency band and hardware components still have to be taken, the impact of these decisions can be observed in the scenarios.

#### 6.3.1.1 Scenario "All expectations met"

In this scenario, all assumptions are based on the current level of awareness concerning the number of installed IVHW units, costs, and customer willingness to pay:

- number of installed units in Germany according to the described penetration rates (4,6 million units till 2007)
- material + integration costs at 35€ per unit for charges of 1 million
- distribution costs at 5€ per unit for charges of 1 million
- all units are installed for free until 2006
- prices at 25€ in 2007 and at 50€ from 2008 on
- development costs of 4 million € before market introduction
- no public support for the system

The market entry strategy can be described as **building up an IVHW network** by installing 2,7 million IVHW systems for free (2003 – 2006) and 1,9 million for a price inferior to the costs (in 2007). Due to network effects, the value of an IVHW system perceived by the customer from 2007 on has risen, which is reflected by the **increasing price**. Since the IVHW functionality is integrated in the car and the navigation system as standard equipment, the explicit price of the IVHW system is not necessarily visible for the customer.

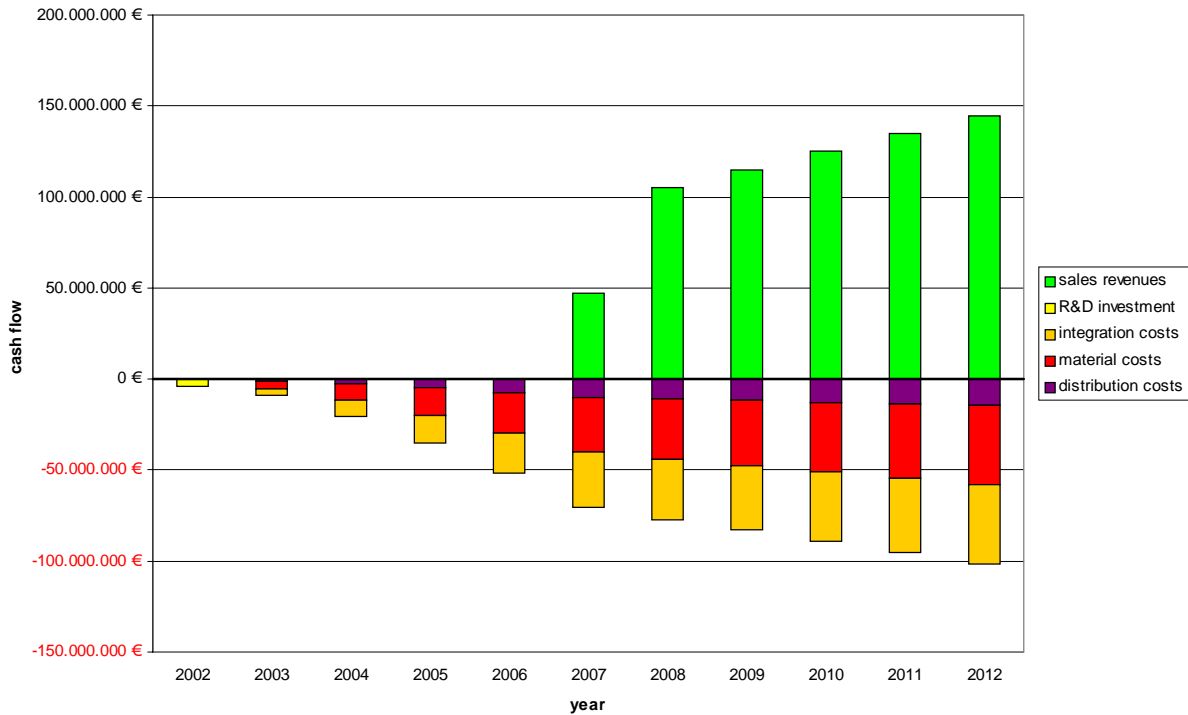

Figure 24 : annual cash flows for scenario “All expectations met”



Figure 25 : cumulated discounted cash flow for scenario “All expectations met”

The first positive margin is achieved in 2008. Before this point, the accumulated discounted investment is 120 million €. Until then, the critical mass of 4,6 million IVHW units is installed. Establishing a constant price of 50€ per unit from 2008 on, the break-even point is reached shortly after 2012.

### 6.3.1.2 Scenario “High customer acceptance”

In order to reach a break even situation earlier than in the preceding scenario, efforts could be aimed at increasing customer acceptance and taking advantage of network effects earlier. For this purpose, the marketing activities could be enforced (doubling the distribution costs) for the sake of sales revenues from 2005 on, with a price objective of 60€ in 2009. All other parameters are left unchanged from the last scenario.

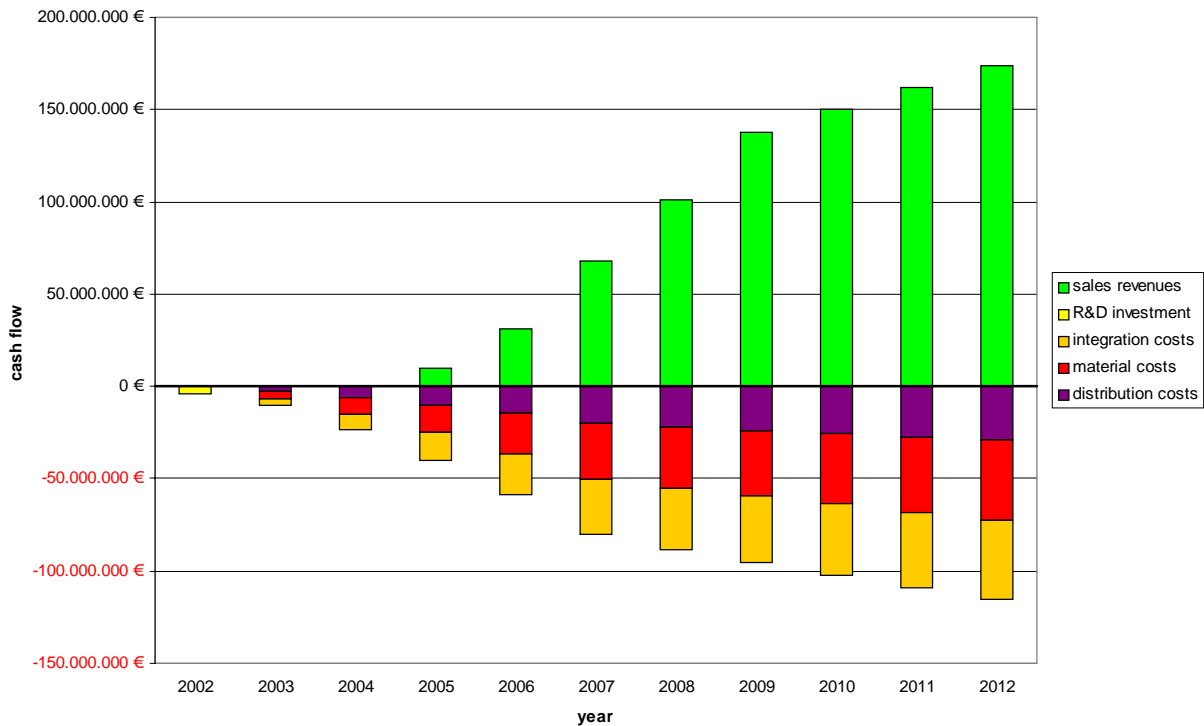

Figure 26 : annual cash flows for scenario “High customer acceptance”



Figure 27 : cumulated discounted cash flow for scenario “High customer acceptance”



The first positive cash flow occurs in 2008, like in the preceding scenario, but thanks to earlier sales revenues the accumulated investments till 2007 are below 100 million €. With an increase of the sales price by 20% from 50€ to 60€, the operating cash flow in 2012 is increased by 32% from 44 million € to 58 million € in comparison with the initial scenario. Break-even is already reached between 2010 and 2011.

### 6.3.1.3 Scenario “Low customer acceptance”

Since the customer behavior is hard to predict, it is also necessary to construct an unfavorable scenario and to evaluate the financial risks connected to the IVHW market introduction. In this case, we start with the same conditions (material, integration and distribution costs, number of installed units till 2006) like in the first scenario. As soon as prices are increased, customers start to reject the system. With a price of 25€ in 2007, one third of the customers is lost. At a price of 50€ from 2008 on, only half of the originally expected customers install the IVHW system, thus cutting turnover and scale effects significantly.

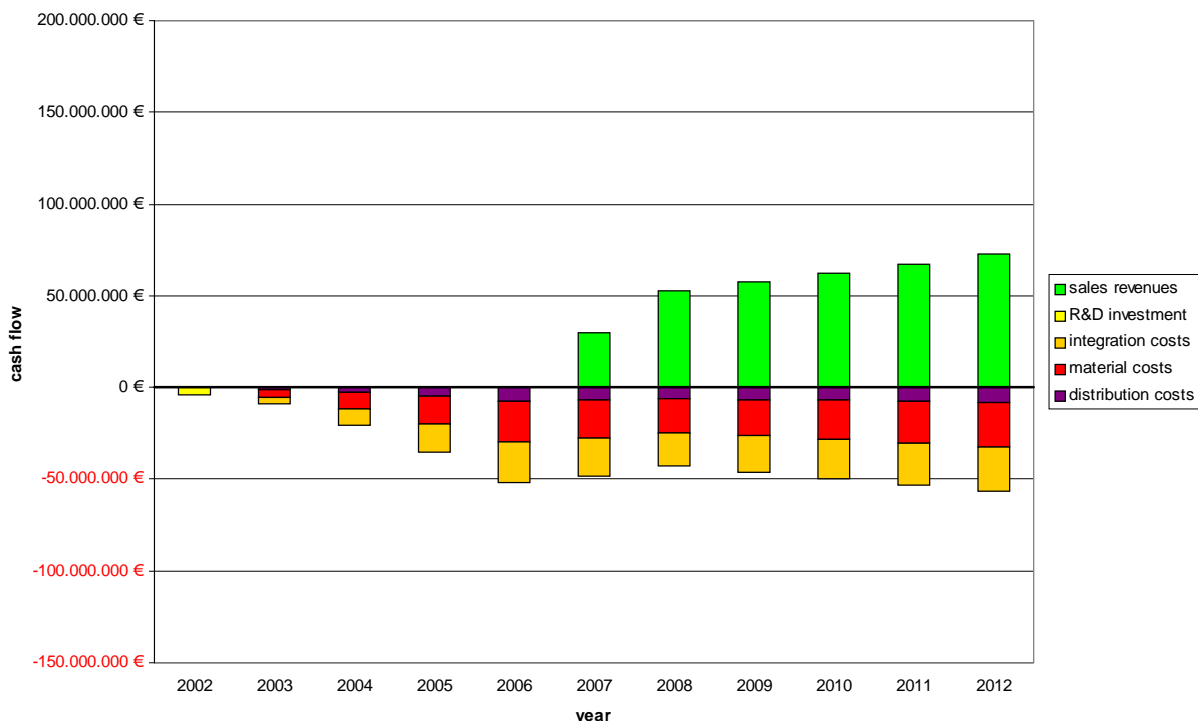

**Figure 28 : annual cash flows for scenario “Low customer acceptance”**

Till 2007, this scenario is identical with “All expectations met”. Installing a critical mass of IVHW systems requires an investment of nearly 120 million €. Afterwards, the system can be sold profitably with a margin of more than 10€ per unit. However, the turnover is far behind expectations, so the break-even point cannot be reached in the considered timeframe. This scenario shows how important it is to know the price sensitivity of the IVHW market.

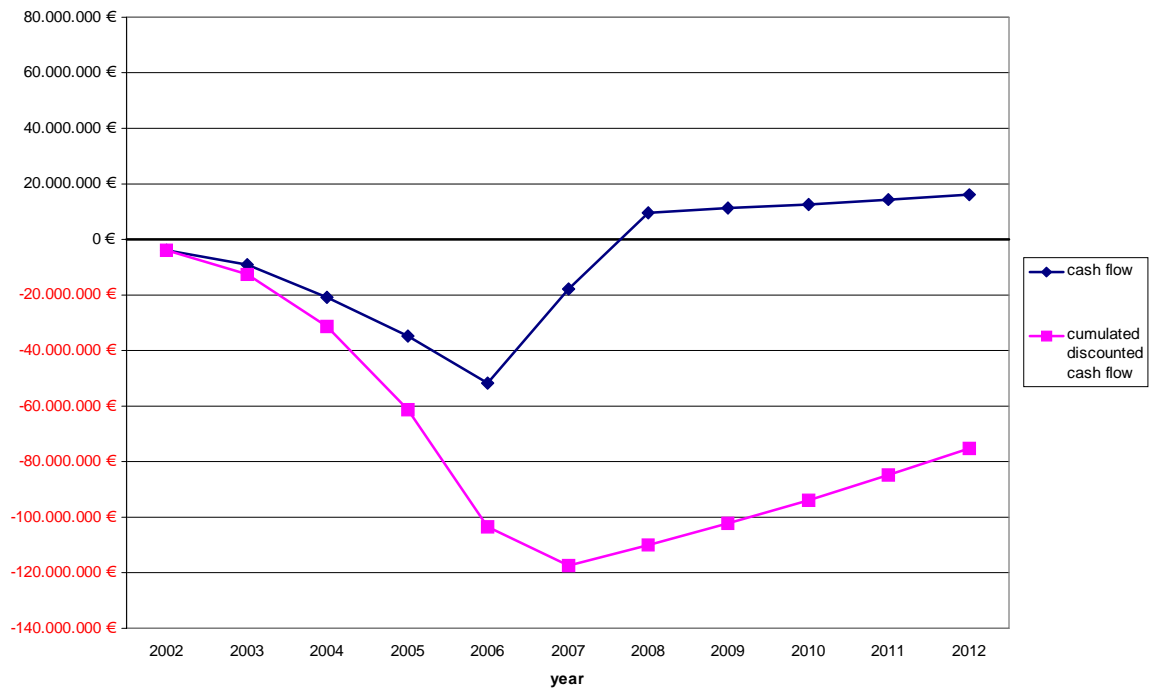

Figure 29 : cumulated discounted cash flow for scenario "Low customer acceptance"

### 6.3.1.4 Scenario "Low cost solution"

So far, the costs for IVHW components and vehicle integration have been left constant at about 35€ per unit for charges of one million. However, if low cost solutions using frequencies in the FM band become available and the car radio antenna is used instead of the GSM antenna, these costs might be brought to 20€, according to the list of materials prepared for the corresponding communication module. With all other parameters left like in the initial scenario, the impact of cost reductions can be observed.

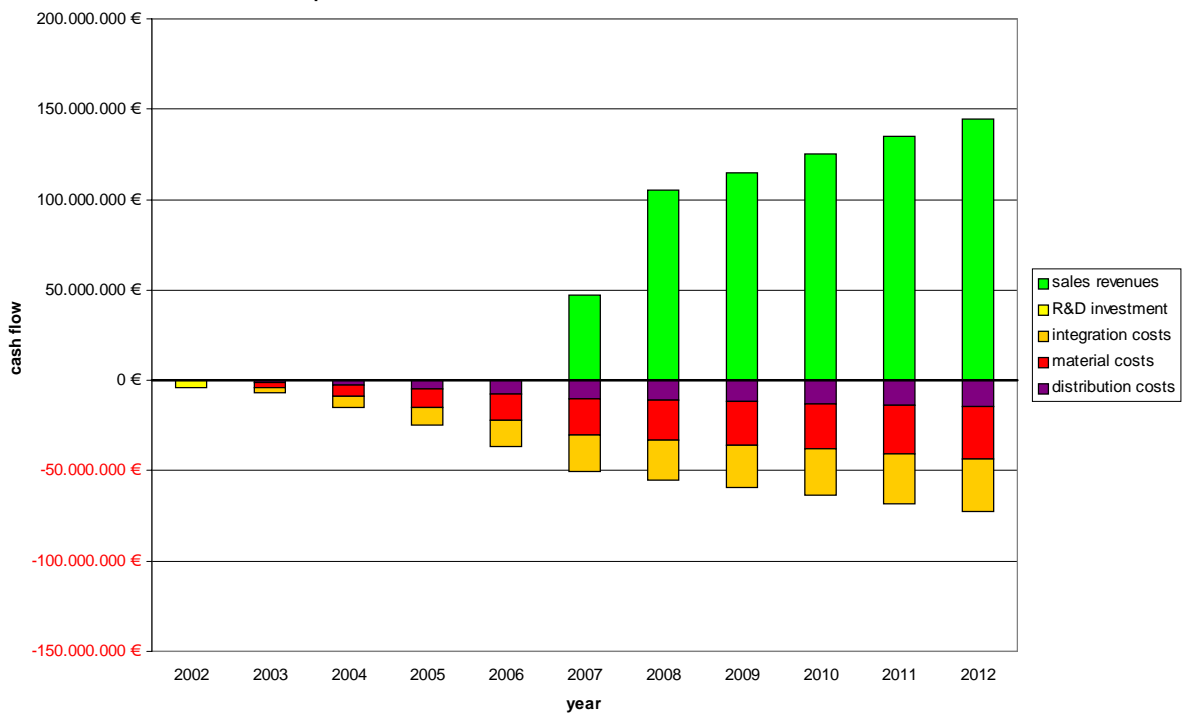
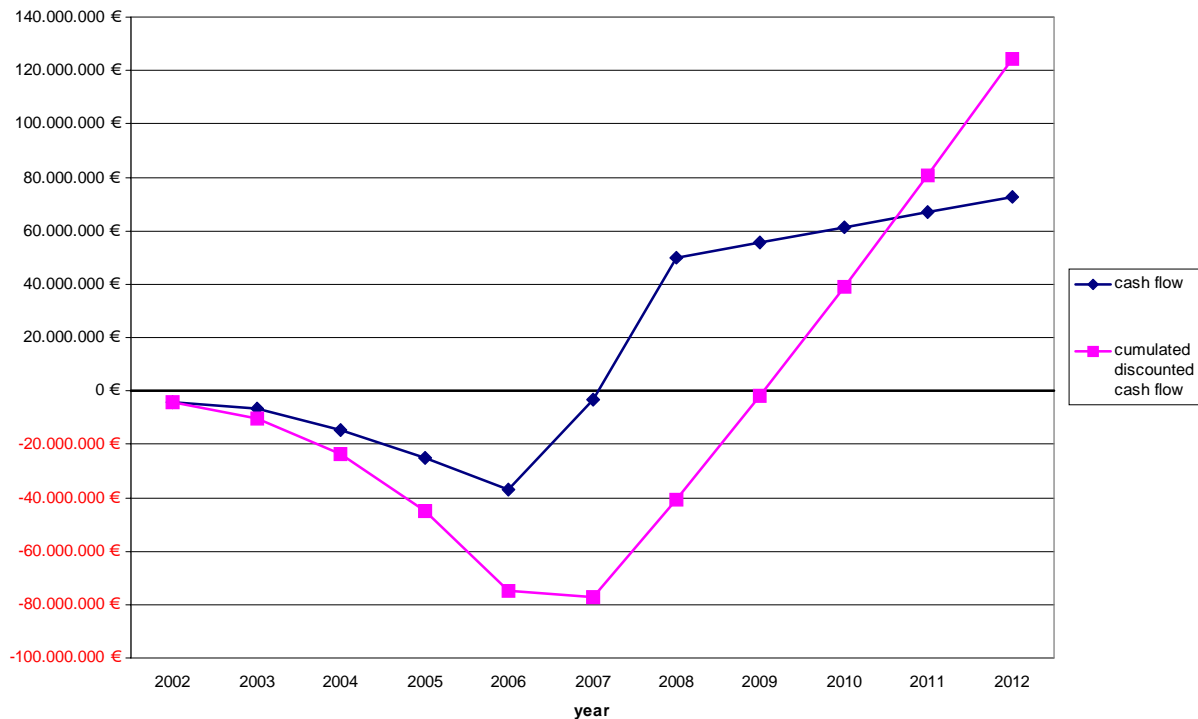

Figure 30 : annual cash flows for scenario "Low cost solution"



**Figure 31 : cumulated discounted cash flow for scenario “Low cost solution”**

The reduced costs are directly increasing the operating margin and shifting the blue curve upwards. The investment to equip the 4,6 million vehicles is below 80 million €. Due to higher margins, the investment breaks even in 2009 already. If customer acceptance is as high as expected, low cost IVHW in combination with positive network externalities turns out to be a very profitable long term investment.

### 6.3.1.5 Scenario “Public financing”

The benefit of the IVHW system is beyond manufacturer profit. IVHW creates additional value through:

- improved safety on the roads
- less injuries / fatalities
- better traffic circulation

The potential annual savings for social costs related to avoided accidents was estimated at 258 million € in Germany if 30% of all vehicles are equipped [1]. It is therefore reasonable to seek public support for this system. The following activities might be subject to cooperation with public institutions:

- research and development (already supported by public funds, Deufrako)
- frequency allocation and license (either at 869,4MHz or at 70-88MHz)
- incentives for customers during IVHW introduction (taxes, price discounts)
- risk reduction for manufacturers during IVHW introduction (public financing)

Obviously, the greatest challenge for the IVHW introduction is the installation of a base of more than 4 million vehicles. Once this investment is made, the value of the created network is higher than the costs for new IVHW installations, but the investor has to carry the risk of low turnovers. At this point, a model is proposed which shifts this risk to the public by financing the investment during the first five years and by taking away a certain percentage of the revenues once the system is sold profitably.

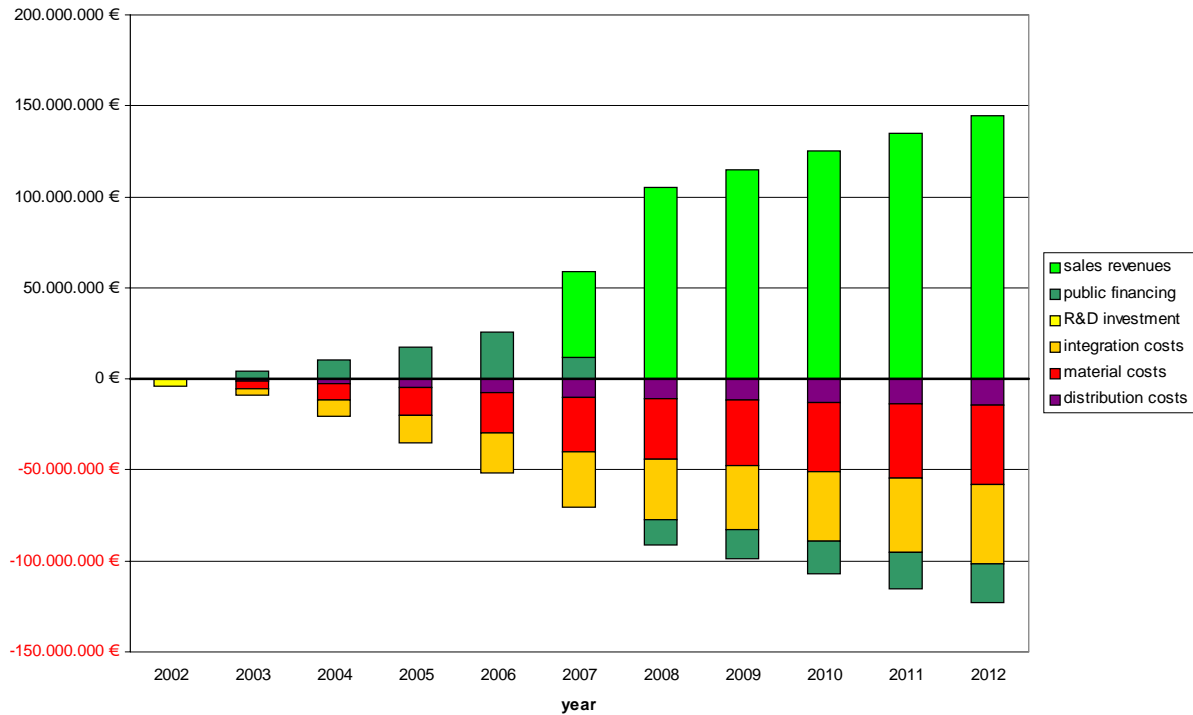

Figure 32 : annual cash flows for scenario "Public financing"

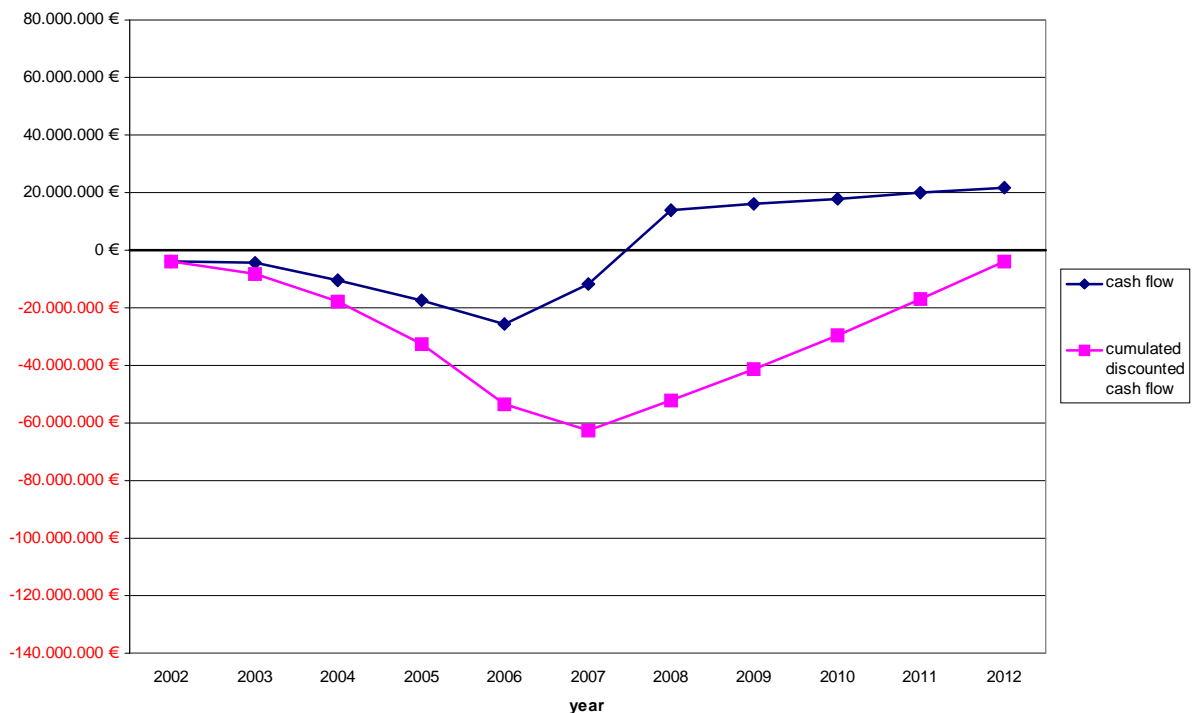

Figure 33 : cumulated discounted cash flow for scenario "Public financing"

In this case, the public holds a 50% share of IVHW, so the investment for the IVHW manufacturer is only half as high. On the other hand, once the system is profitable, the public obtains the corresponding share of revenues. The resulting cash flow is equal to the initial scenario, but only one half of it is carried by the manufacturer. Many instruments of public financing are conceivable, for example fixed credits during the investment with predetermined payments, tax reductions or bonuses for IVHW customers. All these measures can help to release some risk from manufacturers, suppliers, and customers.

## 7 Conclusion

The analysis of the potential IVHW market can be summarized in three statements:

- 1) **The potential penetration rates of IVHW on motorways five years after market introduction are 11% for Germany and 5% for France, only considering cars.**
- 2) **Successful market entry requires the installation of a critical mass of IVHW systems (around 4,6 million units in Germany) before there are revenues from customers.**
- 3) **Low system costs (<40€ for material, integration, and distribution per unit in charges of 1 million) and high customer acceptance (network effects compensate for price sensitivity) are the key success factors for an investment in IVHW.**

The market introduction of IVHW has to be prepared carefully. Only by joint efforts of all involved parties, the predicted penetration rates can be achieved in Germany and France. In any case, the first step consists in distributing IVHW systems for a reduced price on different platforms. For this purpose, the following steps have already been performed:

- proposals of feasible frequency bands and design of communication module
- cost estimations for various designs
- impact assessment and evaluation of IVHW
- demonstration of IVHW in vehicles
- standardization proposals
- estimation of potential market penetration rates
- assessment of different market entry scenarios

Based on the results of the preceding work packages, the following actions need to be taken in order to proceed with the IVHW implementation:

- **Final decision for the IVHW frequency band, taking the results of cost estimations into account:** The frequency band is the major factor driving the costs for IVHW components and vehicle integration. Knowing the cost estimations for the solutions suggested so far and the corresponding investments, the final decision has to be based both on technical and economic feasibility.
- **Possibly efforts for IVHW license at FM frequency (70 – 88MHz):** In case of a decision for a frequency in a restricted band, initiatives towards licenses in whole Europe are crucial for the long term success of IVHW.
- **Cooperation with major manufacturers of navigation systems in order to include the IVHW core and a suitable HMI:** As identified earlier, navigation systems and infotainment units are ideal platforms for IVHW realizations
- **Market research to determine customer acceptance and price sensitivity:** IVHW cannot be introduced by force. An extensive knowledge base about customer expectations concerning functionality, reliability, safety, comfort, and price has to be available to create a successful design.
- **Negotiations with public institutions concerning support for market introduction:** The potential savings in social costs by a reduction of accidents are a strong argument. Public support can be seen as the key to unlock the market implementation process and to manage the risks connected with IVHW market introduction.

## Abbreviations

CAN	Controller Area Network
ERC	European Radio Communications Community
ERP	Emitted Radiated Power
ETC	Electronic Toll Collect
EUCAR	European Council for Automotive Research & Development
FM	Frequency Modulation
FSK	Frequency Shift Keying
GPS	Global Positioning System
GSM	Global System for Mobile Communication
HF	High Frequency
HMI	Human-Machine Interface
IPA	Injury Producing Accident
ISM	Industrial Scientific Medical
IVHW	Inter-Vehicle Hazard Warning
OEM	Original Equipment Manufacturer
RF	Radio Frequency
SRD	Short Range Device
WP	Work Package

## References

- [1] Impact Assessment and Evaluation, Deliverable 1, IVHW Consortium
- [2] System Concept Specification, Deliverable 2, IVHW Consortium
- [3] Implementation Issues, Deliverable 3, IVHW Consortium
- [4] Communication Technology, Draft 02, April 2002, IVHW Consortium
- [5] IVHW, a new system for safety, Compact Disc Presentation 2002, IVHW Consortium
- [6] IVHW System Concept and Issues relevant for Standardization, September 2002, IVHW Consortium
- [7] Estimated Market Penetration Rates for Navigation Systems and Telematic Platforms for Motorway Traffic in Germany, Draft 01, September 2001, IVHW Consortium
- [8] RF-Modem with CAN-Bus link for IVHW, October 2002, Robert Bosch GmbH
- [9] DRI World Car Sales Forecast Report, April 2002, DRI-WEFA
- [10] DRI World Car Industries Forecast Report, June 2002, DRI-WEFA
- [11] Verkehr in Zahlen 2000, Bundesministerium für Verkehr, Bau und Wohnungswesen
- [12] Internationales Verkehrswesen 3/2000, Deutscher Verkehrsverlag
- [13] Wirtschaftswoche, Nr. 17, April 2002
- [14] Sauter, M.: Internationale Markteinführung technologischer Innovationen – eine Management-Konzeption, Shaker Verlag, 2001
- [15] Shapiro, C; Varian, H.R.: Information Rules – A Strategic Guide to the Network Economy, Harvard Business School Press, Massachusetts, 1999
- [16] Varian, H.R.: Intermediate Microeconomics, 5<sup>th</sup> Edition, W. W. Norton & Company, Inc., New York, 2000

# WP 1

## System Concept Specifications

### Deliverable

Document number:	ivhw_WP1_deliverable_final_issue2.doc	
Report number:	D2.0	
Document version:	Issue 2	
Status:	Final	
Dissemination level:	INTERNAL IVHW Consortium French and German authorities	
Date of preparation:	31/01/02	
Authors:	Name	Organisation
	C. Brenzel	Robert Bosch GmbH
	R. Schuessler	Daimler Chrysler AG
	D. Seeberger	Daimler Chrysler AG
	J. Linkohr	Daimler Chrysler AG
	I. Becker	Daimler Chrysler AG
	B. Maisseu	Renault
	C. Chakara	PSA
	T. Guillemot	ESTAR
	M. Chevreuil	ISIS



## TABLE OF CONTENTS

1. EXECUTIVE SUMMARY .....	1
2. INTRODUCTION .....	3
2.1 objectives .....	3
2.2 Reference documents .....	3
2.3 Abbreviations and acronyms .....	3
3. OUTLINE OF THE SYSTEM.....	5
3.1 Definition of IVHW / Overall system concept.....	5
3.2 System Design Philosophy.....	5
3.3 Conditions of use .....	5
3.3.1 Scenario 1: any situation where the driver estimates that activating the warning flashers is worthwhile. ....	6
3.3.2 Scenario 2: Vehicle breakdown or accident .....	6
3.3.3 Scenario 3: warning beacon scenario .....	7
3.3.4 Scenario 4: Airbag triggering .....	7
3.3.5 Other automatic scenarios.....	8
3.4 Design constraints.....	8
3.4.1 Activation only by the driver (normal situations) .....	8
3.4.2 Automatic triggering (in critical situations).....	8
3.4.3 Mandatory coupling with warning flashers .....	8
3.4.4 Deactivation of IVHW (Manually triggered) .....	8
3.4.5 Deactivation of an IVHW transmission (automatically triggered).....	8
3.4.6 Protection of Privacy.....	9
3.4.7 Hazard classification only on receiver side .....	9
3.4.8 Information on positions sent out.....	9
3.5 Expandability.....	9
3.5.1 Extending the IVHW Message content .....	9
3.5.2 Extending hardware features .....	9
3.6 Interoperability in Europe .....	10
4. IVHW FUNCTIONALITIES .....	11
4.1 Message process (emitting a warning message).....	11
4.2 Message process ( receiving a warning message).....	12
4.3 Interface with infrastructure based systems .....	12
4.3.1 Description.....	12

4.3.2 Design characteristics.....	13
4.4 Message content.....	13
4.4.1 Introduction.....	13
4.4.2 Summary .....	13
4.4.3 Message id: .....	14
4.4.4 Hazard type: .....	14
4.4.5 Geographic location n:.....	15
4.4.6 Road type .....	15
4.4.7 Road id .....	15
4.4.8 Direction .....	15
4.4.9 Speed .....	15
4.4.10 Extension .....	16
5. COMMUNICATION TECHNOLOGY.....	17
5.1 Communication equipment.....	17
5.1.1 Requirements .....	17
5.1.2 Hardware specification .....	18
5.2 Regulations .....	18
5.3 Protocol.....	20
5.3.1 Channel access .....	20
5.3.2 Messages .....	20
5.4 Message Transfer .....	21
5.5 Error protection .....	21
5.5.1 Communication Technology Conclusion .....	21
6. VEHICLE INTEGRATION .....	22
6.1 On-board system architecture .....	22
6.1.1 IVHW-Core .....	22
6.1.2 GPS Data Source .....	24
6.1.3 Communication Device .....	24

## PICTURES

Picture 1: system context diagram .....	5
Picture 2: "enhancement of warning flashers" .....	6
Picture 3: virtual warning triangle.....	6
Picture 4: warning from infrastructure.....	7
Picture 5: airbag triggering .....	7

---

Picture 6: system architecture .....	22
Picture 7: process model.....	23
Picture 8: IVHW as Add-On.....	24

**TABLES**

Table 1: message content .....	14
Table 2 : Basic requirements of the communication module .....	17
Table 3 : Technical specification of the radio module .....	18
Table 4:National restrictions .....	19
Table 5:ERC Recommendation 70-03: Relating to the use of short range devices .....	19
Table 6:Message format, size in bits .....	20

## 1. EXECUTIVE SUMMARY

The aim of IVHW project presented is to jointly design and evaluate a common concept for an Inter- Vehicle Hazard Warning system giving precedence to European highway traffic and also to assess its possible market introduction, taking into account costs and effectiveness.

The project is conducted by a Franco-German consortium within the DEUFRAKO program. It is a two-year project, that started in January 2001.

The concept of IVHW that has been developed is based on a peer to peer communication between a "vehicle emitter", in which the driver spots a hazard (or is in a hazardous situation) and a "vehicle receiver"), or several vehicles. The warning message sent includes various attributes specifying its situation (location, speed, course, ...) and - the type of hazard encountered, that allow the receiver(s) to characterise the hazard according to its own situation. This characterisation is achieved by the receiving vehicle through various filtering techniques to reduce non relevant warning messages as much as possible (receiving when downstream of the hazard spot, hazard on the opposite direction of the motorway, quite far from the hazard, ...).

In theory, a warning message can be activated manually or generated automatically from an on-board computer able to characterise a hazardous situation.

In IVHW, the manual activation constitutes the basis for the IVHW system development. This is a deliberate choice made to develop within a short time period a workable, low cost "preferable OEM" solution. However, the system should be open to future developments based on automatic activation and as a first application case, the air-bag triggering is already considered.

The domain of use of the inter-vehicle hazard warning system is mainly motorways and expressways where consequences of collisions on fixed or moving obstacles are in general more severe due to the traffic speed. Of course this includes urban expressways.

Besides the following constraints that have been fixed by the partners:

- Activation only by the driver: the driver decides if an incident deserves a warning or not
- Automatic triggering only if no doubt that the situation is critical: at present only in situations where an airbag is activated,

additional requirements have been introduced:

- Mandatory coupling with warning flashers: to simplify driver's task and to reduce misuse potential
- Automatic deactivation only to avoid communication channel overload: if up-stream warning by other vehicles is verified
- Protection of privacy: no personal identification
- Hazard evaluation only on the receiver side: due to liability reasons

Concerning communication bearer, investigations have led to identify a candidate frequency band: 869.4 - 869.65 MHz. The basic conditions for the use of this are defined in the ERC Recommendation 70-03, published by the European Conference of Postal and Telecommunications Administrations (CEPT) and which is implemented by the most European countries. There exist following national restrictions (status of May 2001): Bulgaria, Greece, Italy, Poland, Portugal, that require to be further investigated.

Starting from this common concept, the IVHW consortium has developed preliminary specifications and initiated investigation on factors that are necessary to build the IVHW

implementation strategy. Four main pre-conditions have been identified for a successful market introduction:

- Perceivable safety benefit for the driver
- Potential global benefits for the community
- Low system costs
- Successful standardisation

## 2. INTRODUCTION

### 2.1 OBJECTIVES

The objective of this document is to present the IVHW system concept specifications. This document draws together the contributions of the IVHW partners involved in WP1 and drafts a first system concept that will form the basis for the WP2 "assessment" to allow the partners to develop the test vehicles and demonstration vehicles during the second year

This deliverable includes four main chapter :

- A first chapter presenting an outline of the system that forms the common basis agreed among the IVHW partners
- A second chapter describing the IVHW functionalities
- A third chapter introducing the communications aspects
- A fourth chapter presenting the main principle concerning vehicle integration

Deliberate choice has been made on simple solutions when possible: with the evolution of in-car systems, the concept of IVHW could be improved in the future, by including more automation. But our agreed objective is to develop within a short time period a workable, low cost "preferable OEM" solution.

In that context, precedence is given to manual use of the IVHW system, in combination with the warning flashers activation.

### 2.2 REFERENCE DOCUMENTS

List of main background documents provided by the partners

- [1] IVHW system design proposal (DaimlerChrysler 280301 version and following comments from partners ): ivhw\_dc\_rb\_psa\_dc\_0423.doc
- [2] IVHW system design proposal (Bosch 060401 version and following comments and answers): ivhw\_sysspec\_prop\_1v2\_dc\_comments\_20010430.doc
- [3] IVHW trace point casting algorithm (DaimlerChrysler contribution to IVHW WP 1 ): ..... new\_point\_casting\_algorithm\_20010731-1.doc
- [4] Communication Technology DRAFT 01 (DaimlerChrysler contribution ): ivhw\_Communication\_Technology\_300801.doc
- [5] Vehicle Integration (PSA): IVHW\_systemintegration\_psaVI02.doc
- [6] System Concept Specification Communication Technology DRAFT 01(ESTAR contribution): ivhw\_communication\_D1.2.2ESTAR.doc

### 2.3 ABBREVIATIONS AND ACRONYMS

ARQ	Automatic Repeat Request / Query
ART	Agence de Régulation des Télécoms (Telecommunications Regulation Agency, France)
CEPT	Conference Européenne des Postes et Telecommunications (European Conference of Posts and Telecommunications)

ERC	European Radiocommunications Community
FEC	Forward Error Correction
GPS	Global Positioning System
GSM	Global System for Mobile communication
HMI	Human Machine Interface
IVHW	Inter Vehicle Hazard Warning
OEM	Original Equipment Manufacturer
TIC	Traffic Information Centre

### 3. OUTLINE OF THE SYSTEM

#### 3.1 DEFINITION OF IVHW / OVERALL SYSTEM CONCEPT

The concept of IVHW that is developed hereafter is based on a communication between a vehicle 1 ("warning emitter"), in which the driver spots a hazard (or is in a hazardous situation) and a vehicle 2 ("warning receiver"), or several vehicles. The warning message sent includes various attributes specifying its situation (location, speed, course, ...) and the type of hazard encountered, that allow the receiver(s) to characterise the hazard according to its own situation. This characterisation is achieved by the receiving vehicle through various filtering techniques.

IVHW CONTEXT DIAGRAM (according to ITS system architecture frameworks)

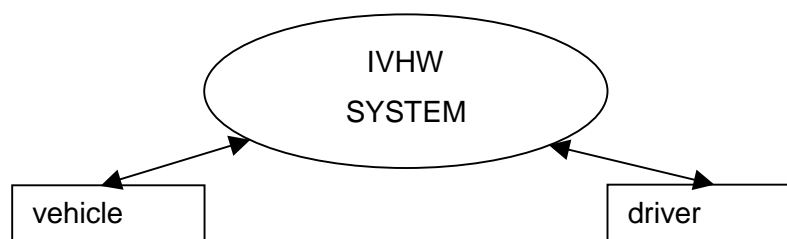

Picture 1: system context diagram

#### 3.2 SYSTEM DESIGN PHILOSOPHY

- The warning function will be activated either by the driver when he feels that he is in a situation that can create a specific danger for coming drivers (and in general for himself), either automatically.
- Automatic triggering an IVHW message transmission will only be used for scenarios in which it is clear that the vehicle is in a hazardous situation. At present, this is well admitted by all for air-bag activation.
- On receiving any information given by the IVHW system, it's on the driver's decision to weigh the information and to react accordingly. The driver remains responsible for his actions.
- The intention of IVHW is to support the driver in foresight.
- The IVHW system is not a technical approach for automatic driving.
- A missing notification about any hazardous situation doesn't mean the absence of any hazardous situation.

#### 3.3 CONDITIONS OF USE

It is not the purpose of the project to define all the conditions of use. The warning function will be activated either by drivers when they feel that they are in a situation that can create a specific danger for coming drivers (and in general for themselves), either automatically. In the later case, the situation of danger is detected by the vehicle according to various parameters measured.



**The manual activation constitutes the basis for the IVHW system development.**

In addition, the use of the warning function by infrastructure based equipment is also possible.

The IVHW systems aims for example at increasing safety in the situations described in the following sub-sections.

### 3.3.1 Scenario 1: any situation where the driver estimates that activating the warning flashers is worthwhile.

The vehicle that sends the warning message is located behind an accident or traffic jam. It either moves at slow speed or stops. Warning flashers are activated.

This scenario corresponds to the INRETS accident scenarios investigated:

- Hold-up, accident
- Catching up with a significantly slower vehicle
- Major incident
- Slowing down traffic

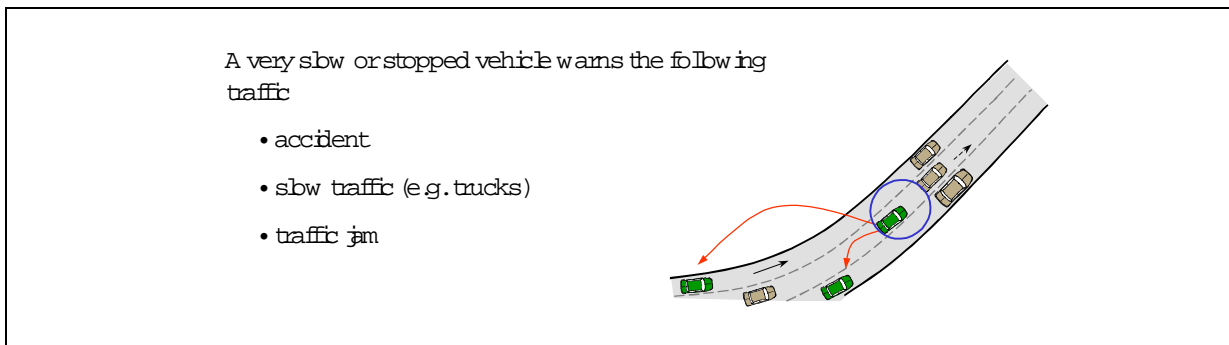

**Picture 2: "enhancement of warning flashers"**

### 3.3.2 Scenario 2: Vehicle breakdown or accident

The vehicle that sends the warning message has stopped on the emergency lane. It uses IVHW to set up a „virtual warning triangle“ at its location to warn the following traffic. To activate IVHW the driver has to activate the warning flashers first.

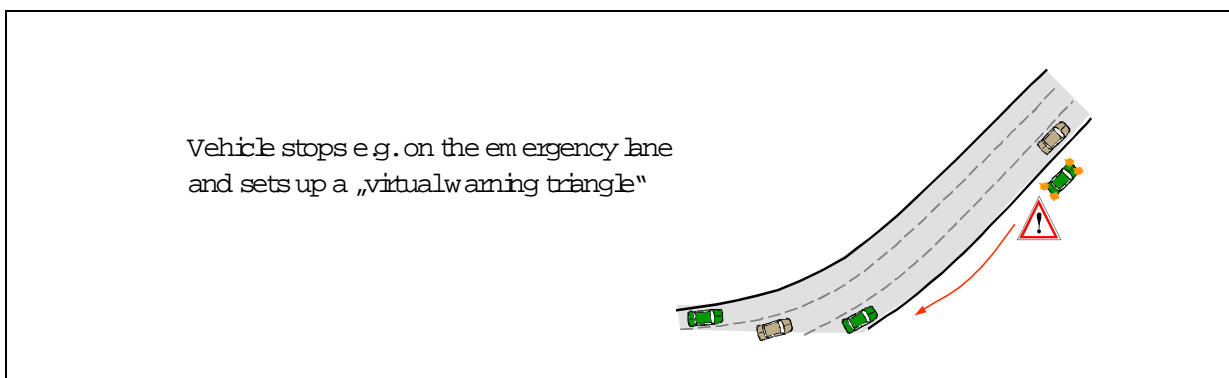

**Picture 3: virtual warning triangle**

### 3.3.3 Scenario 3: warning beacon scenario

As IVHW aims at designing a simple solution for hazard warning, the integration of roadside beacon is seen as a possible extension.

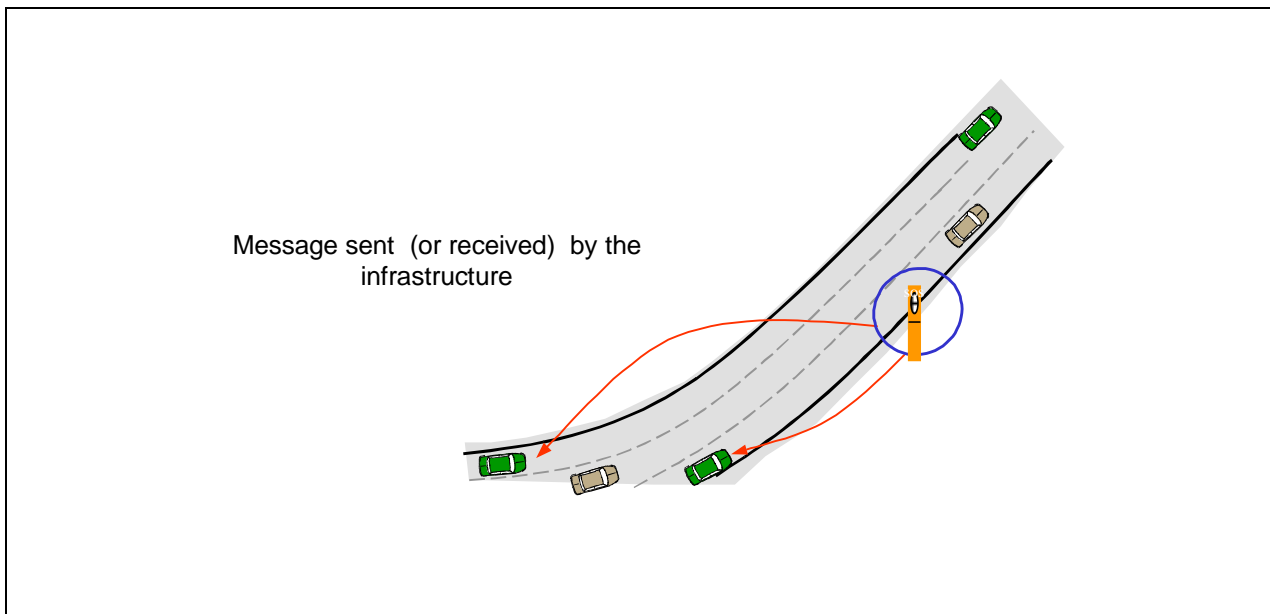

Picture 4: warning from infrastructure

### 3.3.4 Scenario 4: Airbag triggering

When an airbag is triggered, IVHW messages are automatically sent, with no time limit and no possibility of deactivation. This case seems very important in order to avoid severe pile-up accidents.

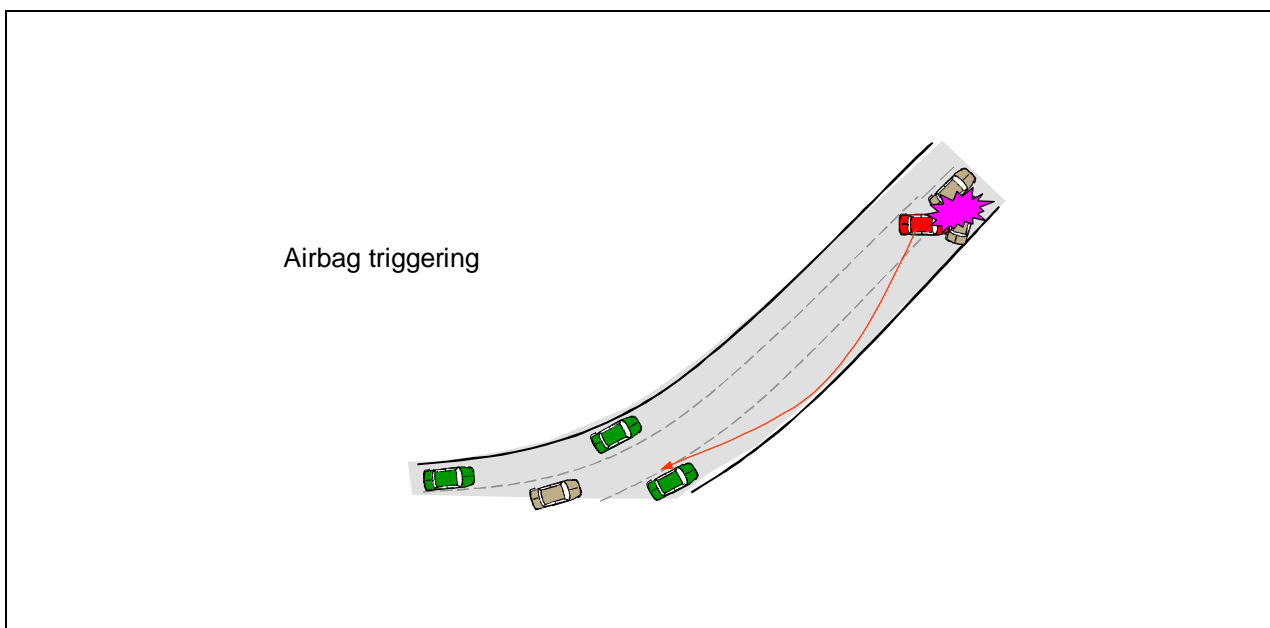

Picture 5: airbag triggering

### 3.3.5 Other automatic scenarios

Assuming that in the future, other hazard situations can be detected by the in-vehicle systems, for activating safety systems such as deploying lateral protection systems, deploying roll bars, tightening seatbelt or emergency braking. Other automatic triggering can be foreseen.

However, as it is not the purpose of IVHW to work on all possibilities, we will assume that IVHW will be open to be triggered by any "warning message" generated by an on-board safety car computer.

## 3.4 DESIGN CONSTRAINTS

### 3.4.1 Activation only by the driver (normal situations)

The driver decides if an incident is relevant and manually triggers the IVHW message transmission.

### 3.4.2 Automatic triggering (in critical situations)

Automatic triggering an IVHW message transmission will only be used for scenarios in which it is clear that the vehicle is in a hazardous situation. At present, this is well admitted by all for air-bag activation. Further automatic activation will be open for future features.

### 3.4.3 Mandatory coupling with warning flashers

IVHW is activated only in combination with the warning flashers. This seems very important for simplifying driver's tasks: if not, the driver would have to select in which situation he should activate the IVHW only, or the warning flasher only, or both.

**The IVHW radio message cannot be released without active warning flashers.** This visual identification may as well contribute to reduce the misuse of the warning system.

Concerning the misuse of the system (and its prevention), it has to be discussed further. It is clear that an optical feedback with warning flasher would not be sufficient.

### 3.4.4 Deactivation of IVHW (Manually triggered)

The broadcasting of the warning message - may only be stopped manually. One exception is an automatic deactivation for avoiding overloading of the data communication bearer: once verification is made that the same message is sent by an up-stream vehicle, the emission can be stopped automatically.

In such a case, the coupled warning flashers are not deactivated

### 3.4.5 Deactivation of an IVHW transmission (automatically triggered)

When an airbag is triggered, IVHW messages are automatically sent, with no time limit and no possibility for deactivation except by the breakdown mechanic. A more sophisticated strategy could be investigated further on if this solution is not easy to implement.

### 3.4.6 Protection of Privacy

The IVHW message does not contain any data that allows the automatic identification of the sender vehicle.

Nevertheless, the ability to distinguish vehicles is important to suppress one and the same alert message sent out by one and the same vehicle. This can be achieved by a random vehicle-ID which is changed, whenever the vehicle is started.

### 3.4.7 Hazard classification only on receiver side

The receiver of an IVHW warning message checks the relevance of the hazard.

- The sender does not have to generate information about relevance for other vehicles.
- Associated liability issues are then minimised.

Rules for classifying the relevant information will be developed in the operating rules section.

### 3.4.8 Information on positions sent out

The message that is sent includes several positions that allows the receiving vehicles to characterise the situation and its relevance.

## 3.5 EXPANDABILITY

The IVHW system specification is open towards additional features. In general, additional system features have to be implemented in such way, that the standard IVHW features are not affected.

### 3.5.1 Extending the IVHW Message content

If additional system features need to add additional information to the message content, an "Extension Bit" must be set to indicate, that additional information is extending the standard message. The additional content must then be located in the extended part of the IVHW message.

### 3.5.2 Extending hardware features

The IVHW system is considered to be implemented as a plug-in for a infotainment system like a onboard navigation system. As a plug-in, IVHW is mainly based on software. Additional Hardware features have to be supported and provided by the target platform. A software upgrade of the hosting target system is necessary in order to support the additional hardware and it's features for IVHW.

For retrofitting, an IVHW device of a certain stage of development will not provide any (backup) peripheral link for future hardware extensions. Nevertheless, if the IVHW device is connected to the vehicle e.g. by CAN-Bus, hardware extension may be realised by connecting additional hardware to this Bus. A software upgrade of the IVHW device is necessary in order to support the additional hardware and it's features. A software upgrade is not foreseen for already built-in IVHW devices.

### **3.6 INTEROPERABILITY IN EUROPE**

The IVHW system shall provide its function within all countries of the European Union (EU).

In countries, where the IVHW radio communication is not in accordance with the national regulations, IVHW should be disabled. For GPS-only systems with no information indicating the actual country, this could be done by the user.

For IVHW systems with information indicating the actual country (the country can be identified with the navigation system or even with another external source such as GSM or radio FM data reception or even by GPS positioning reproducing roughly the border lines) , IVHW could deactivate itself.

Event coding, indicating which hazard has been occurred, has to be equal and unique amongst all IVHW devices (mobile or infrastructure).

## 4. IVHW FUNCTIONALITIES

The herein presented flow charts are for an overview of the general functionalities only. The algorithms are described in detail into the project's background papers.

### 4.1 MESSAGE PROCESS (EMITTING A WARNING MESSAGE)

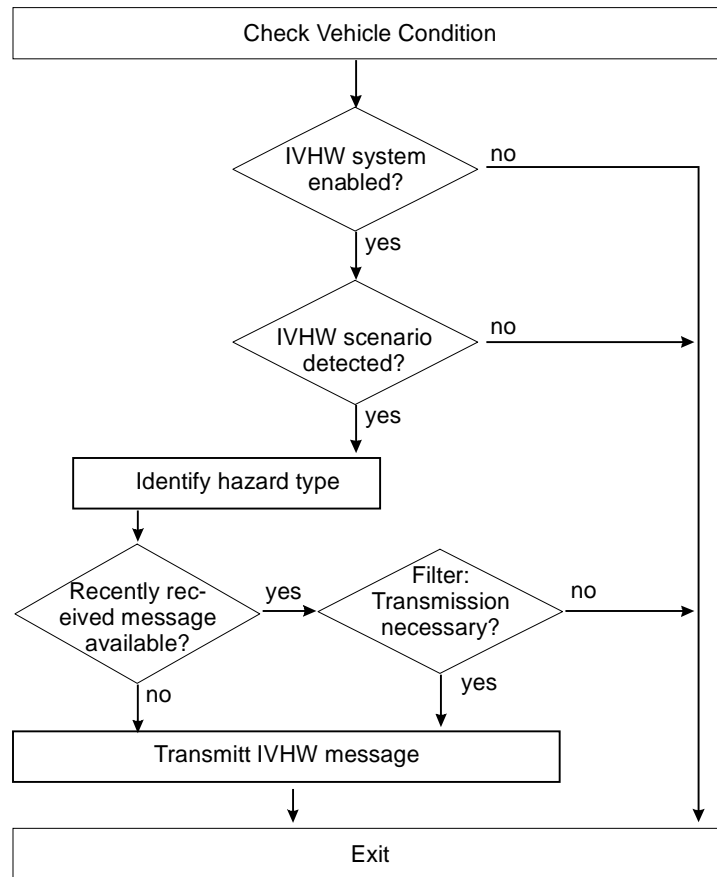

**Fig 1: emitting a warning message**

## 4.2 MESSAGE PROCESS ( RECEIVING A WARNING MESSAGE)

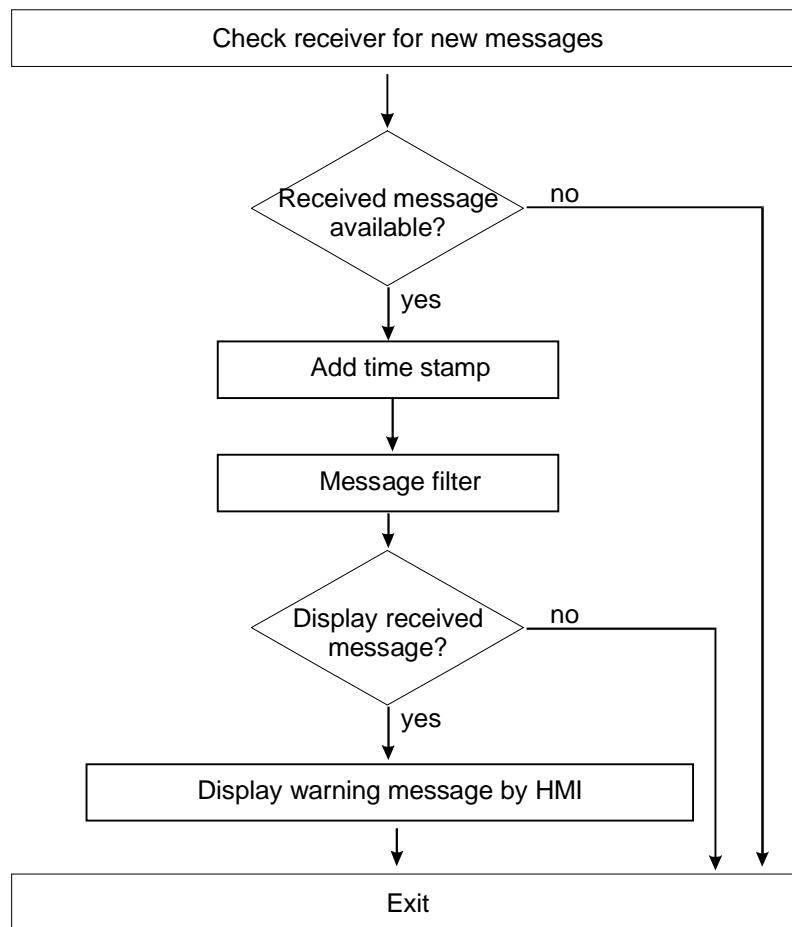

**Fig 2: receiving a warning message**

## 4.3 INTERFACE WITH INFRASTRUCTURE BASED SYSTEMS

This section describes how the infrastructure can transmit warning messages to drivers within a vehicle to vehicle communication system assuming a low IVHW equipment rate and/or light traffic conditions on a given road.

### 4.3.1 Description

The infrastructure warning system is composed of an emitter / receiver module similar to those fitted in vehicles and equipped with a GPS device.

It will be integrated for instance, in a structure of an emergency phone call box.

This system has two communication interfaces :

- a wireless one to transmit warning messages to IVHW vehicles in a 1 km range
- a fixed connection (likely a fibre optic connection) to the Traffic Information Centre (TIC) in order to transmit the events received from IVHW vehicles.

A dedicated application has to be developed in the TIC. This server with an HMI shall decode messages transmitted by the roadside emergency warning module.

In the 'Uplink' mode (IVHW vehicles to roadside IVHW system to TIC), the messages transmitted are in GPS co-ordinates format and shall be decoded on the HMI of the server in XY format with the following attributes : motorway identifier, direction, location and type of incident.

In the 'Downlink' mode (TIC to infrastructure module to equipped vehicles), the application server sends the position of the incident and not the position of the roadside module. Consequently, the on-board IVHW system in the vehicle shall be able to decode the message sent by the application server and which contains the incident position regarding the roadside module location known by the server.

This process should be ensured without affecting real time performance.

The coding of data attributes is recommended through the wireless interface.

A priority mechanism should be applied in the application server during the receiving phase. It will be consistent with the hazard type numbering implemented in the on-board IVHW devices.

### **4.3.2 Design characteristics**

Activation by the TIC operator

After reception of the messages coming from the infrastructure, the TIC operator manually triggers the warning message transmission to the other IVHW vehicles.

Deactivation process of the IVHW roadside module

The deactivation of the received infrastructure based message is done on the same basis as the messages received from the other vehicles

Presentation of infrastructure based messages

The messages transmitted by the emergency roadside module should be identified as such and differentiated from messages send by other vehicles.

## **4.4 MESSAGE CONTENT**

### **4.4.1 Introduction**

This chapter only gives the application (layer seven) and layer two oriented contents of the IVHW-message. All the other aspects concerning the layer one (header, error coding, ...) are addressed in the following section.

### **4.4.2 Summary**

The following table shows the message content agreed by the partners during the first year of the project. This content is subject to modification during the second year if serious difficulties are encountered during the implementation for the tests.



Layer	Information	Size (bits)	Byte number
2	Message id	10	0-1
7	Hazard type	6	
7	Geographic location n	24	2-4
7	Geographic location n-1	24	5-7
7	Geographic location n-2	24	8-10
7	Road id	24	11-13
7	Direction	6	14-15
7	Speed	6	
7	Road type	3	
2	Extension	1	

**Table 1: message content**

If the radio channel quality allows it without lowering the rate of successful transmissions, the chain of three following geographic positions will be transmitted. If this is not possible, the geographic location n-1 and n-2 will not be transmitted. Furthermore the optimum choice of the values n, n-1, n-2 has to be tuned with more attention. These issues will be solved after further field trials.

Thus, the total size of the layer seven and layer two contents of the message is 128 bits.

#### 4.4.3 Message id:

10 bits

A succession of re-emitted messages will be marked with the same message id. A new value of this message id is randomly generated each time the car starts and it is incremented by each IVHW triggering. This information is used by the receiver to be able to distinguish two different series of messages and to discard an already received message.

#### 4.4.4 Hazard type:

6 bits

Automatic cases values:

-00 Accident (automatic triggering because of airbag)

Manual cases values:

-01 Warning (most manual cases)

-02 Virtual warning triangle (or vehicle stopped on the emergency lane)

#### 4.4.5 Geographic location n:

24 bits

This field contains a truncated GPS position computed at the second n.

12 bits for latitude

12 bits for longitude

These twelve bits are three decimal digits of four bits each (BCD: binary coded decimal), one digit for minutes and two for seconds. This means a precision of thirty meters in squares of eighteen kilometres (18km>>maximum range of the system).

#### 4.4.6 Road type

3 bits

This field is filled easily if the emitter has a navigation system, otherwise advanced software algorithms evaluating speed and course profile history could allow to determine this road category:

- Motorway
- Highway
- Rural road
- Urban area
- Type information not or still not valid

#### 4.4.7 Road id

24 bits

This contains four characters chosen from a reduced character set coded with six bits only.

#### 4.4.8 Direction

6 bits

This is the absolute direction by compass calculated from the GPS-Information. 360° is divided into 60 segments of 6°.

Note: The way the direction is computed has to be complementary with the geographic location transmitted: if the geographic locations n, n-1 and n-2 are transmitted, the direction can usefully be computed with geographic location n and n-3. On the contrary, if only one geographic position is to be transmitted or geographic positions n, n-2 and n-4 for example, the direction can be computed with geographic location n and n-1. Further field trials will give better information.

#### 4.4.9 Speed

6 bits

0 to 310km (5km precision), 63 (=315 km) being "more than 310 km".

**4.4.10 Extension**

1 bit

The extension bit indicates that an extended message is following. This extended message could include further features and information for advanced IVHW-systems.

## 5. COMMUNICATION TECHNOLOGY

Communications aspects have been investigated deeply by IVHW partners and detailed reports have been issued [4] [6] []. This section summarises the results of these investigations.

### 5.1 COMMUNICATION EQUIPMENT

#### 5.1.1 Requirements

The basic requirements of the communication module result from the features of the IVHW application listed in the following table:

Communication distance:	at least 1 km, also without line of sight
Communication direction	Unidirectional
Antenna-type	Omnidirectional
Communication mode	broadcast, selection of the relevant messages will be done by the receiver
Size of a warning message:	about 25 Byte information data
Maximum number of warning incidents in the communication range:	10 simultaneously hazards
Advance warning time:	5-10 s before the receiver reaches the hazard location
Maximum speed	250 km/h
Communication fee:	no costs for transmission of warn-messages
Permission area:	Europe
Equipment:	no additional car antenna if possible and sharing the GSM-Antenna of the vehicle if possible (using antenna splitter). Dedicated internal antenna will be investigated in year 2 by Bosch.

**Table 2 : Basic requirements of the communication module**

For a vehicle going with 250 km/h = 69,4 m/s an advance warning time of 5 – 10 s results in a distance of 347 – 694 m. This is still below the required communication distance of 1000 m. The warning messages have to be retransmitted periodically to ensure, that all vehicles coming into the warning zone will be informed. Even not the first, but the second warning message can be received properly, the required advance warning time will be met with a message retransmission of 1/s.

The requirement of the maximum number of warning incidents in the communication range has some impact on the message retransmission rate and the required data rate. Normally a hazard will be reported by more than one vehicle. For a draft estimation the following parameter will be taken:

Message retransmission: 1/s

RX/TX switching, synchronisation and the channel access for each message 30 ms

Transmission of a message with 25 data Byte and a code rate of  $\frac{1}{2}$  at 19.2 kbit/s: 20 ms

The transmission of one message takes about 50 ms. If 2 vehicles report about the same hazard, 10 different hazards may occur in the warning zone with a radius of 1 km.

### 5.1.2 Hardware specification

There exist a European frequency band at 869.4 - 869.65 MHz for non-specific short range devices with a maximum transmission power of 500 mW e.r.p.. The channel spacing is 25 kHz. For high speed data transmission also the whole frequency band may be used. This licence free frequency band is a well suitable basis of a communication module, which fits the requirements of a IVHW system.

Bandwidth:	25 kHz
Transmission Power:	500 mW
Modulation:	FSK (GMSK)
Communication Mode:	Half-Duplex, always listening, while not sending
Switching Delay:	< 10 ms
Channel Access:	Carrier Sense, Random delay
Transmission:	Broadcast
Datarate on air:	19,2 Kbit/s
Error Protection:	CRC (FEC after further investigations channel behaviour)
Interface:	RS 232, 8 Bit, 1 Stopbit, No parity, Hardware-Handshake, 19.2 kbit/s
Range	1000 m without line of sight
	only single hop, no retransmission
Antenna:	Omnidirectional, external (same as GSM)
Power:	12 V (42 V in near future)
Channel coding	Manchester, NRZ or preferably FM0-coding.

**Table 3 : Technical specification of the radio module**

The interface of the communication module is not necessarily an item for the standardisation of IVHW. It is listed here for the sake of completeness.

## 5.2 REGULATIONS

The basic conditions for the use of the frequency band at 869.4 - 869.65 MHz are defined in the ERC Recommendation 70-03, published by the European Conference of Postal and Telecommunications Administrations (CEPT) and which is implemented by the most European countries. The following national restrictions do exist (status August 2001) :

Bulgaria	Not implemented	
Estonia	Voice, audio and video only on frequencies above 2.4 GHz	
Germany	Transmission of audio and voice signals excluded	
Greece	Not implemented	Government use
Italy	Max 25 mW erp	Military applications
Latvia	ERP < 10 mW	
Poland	Not implemented	WLL usage, Implementation planned

**Table 4:National restrictions**

Frequency:	869.4 – 869.65 MHz
Bandwidth/Channel:	25 kHz
Transmission Power:	500 mW e.r.p
Licence:	no licence fee
Type Approval:	Free circulation
Duty Cycle:	< 10 %
Max. cont. transmission:	36 sec
Standard:	EN 300 220-1(Technical Characteristics and test methods) R&TTE Directive for countries which have implemented ERC/DEC/(01)04 (see in annex)

**Table 5:ERC Recommendation 70-03: Relating to the use of short range devices**

In France and Germany the national authorities decide mainly in line with the ERC Rec. 70-03. The national regulations are published in the following documents:

France ART 99-567

Germany Vfg 81/1999 (Amtsblatt Reg TP Nr. 12/99)  
Vfg 123/1999 (Amtsblatt Reg TP Nr. 14/99)  
Vfg 52/2000 (Amtsblatt Reg TP Nr. 9/00)

The whole bandwidth (869.4 – 869.65 MHz = 250kHz) may be used for “high speed data transmission”. As we have discussed with the German regulation authorities, using the whole bandwidth in one channel should provide a data rate which is equal to the sum of all channels.

## 5.3 PROTOCOL

### 5.3.1 Channel access

In the idle state all IVHW-radios will be in the receive mode to be prepared for the reception of warn-messages. Normally there will be no traffic on the radio channel. But if a warn-event occurs then several vehicles will try to send warn-messages. Especially if there is an accident with airbag release the affected vehicles will initiate the transmission of warn messages exactly at the same time. There is a strong need to regulate the access to the RF medium not to block the channel by collisions.

To overcome the problem of simultaneous channel access following collision avoidance strategy will regulate the access to the RF medium:

1. A radio, which is not transmitting, should always listen the radio channel to receive possible warning messages of other transmitters.
2. A radio wanting to transmit a warning message starts doing a carrier sense to check whether the RF medium is busy. The RF medium is considered to be free if the input power is below a certain level for a randomly selected duration. The different duration of the carrier sense will avoid the problem with the simultaneous automatic activation after an accident. Both parameters, the time frame for the carrier sense and the level of sensitivity of the carrier sense are tbd.. The required level of sensitivity depends on the communication range of the radios and on the traffic on the radio channel caused by other applications using the same frequency. The duration has to be limited to a certain period of time in order to prevent the system from internal hook-up.
3. If no carrier is sensed for the randomly selected duration, the radio starts immediately with the transmission of the warning message. After that the radio will switch back to the receive mode.
4. If a carrier is sensed, the radio will go on doing carrier sense until the RF medium is free for the randomly selected duration. Then the procedure goes on with step 3.

### 5.3.2 Messages

The format of the IVHW radio message is shown in Table 1: message content In the following chapters the different fields are explained.

Preamble	Start	Data	Extension bit
144	8	175	1

**Table 6:Message format, size in bits**

#### 5.3.2.1 Preamble

The preamble is required for the bit synchronisation. An alternating transmission of two binary "zero" and two binary "one" allow a robust synchronisation. The time required for the bit synchronisation depends very much on the implementation. The maximum size of the Preamble should be 18 byte.

#### 5.3.2.2 Start

The start word indicates the beginning of the warning message: 00 011 011.

### **5.3.2.3 Data**

The size of the data field is 175 bit. The content of this field is explained in 4.4

### **5.3.2.4 Extension bit**

The extension bit indicates that an extended message will follow. This extended message may include further information for future advanced IVHW-Systems but will not be specified in this version. The default value of the extension bit is "0" and the extended message is indicated by "1".

In the current IVHW version the extension bit will not be considered.

## **5.4 MESSAGE TRANSFER**

In the idle state the communication module will be in the receive mode. All received correct warning messages will be passed to the IVHW-controller. Corrupted messages will be discarded.

On Request the communication module starts with the periodical transmission of a warning message. The period for retransmission is 1 s. Each transmission starts with the channel access procedure described in Chapter 0. The retransmission of a warning message will be stopped on request.

## **5.5 ERROR PROTECTION**

The transmission of warning messages is done in a broadcast modus. Therefore ARQ-procedures for error correction are not possible.

FEC-techniques consume a considerable portion of the channel capacity. The selection of a proper FEC-procedure for IVHW requires an exact knowledge about the statistical error behaviour of the radio channel. An unpropitious designed FEC-procedure may deliver too much erroneous messages misleadingly as correct. This topic will be investigated in deep in Deufrako Year 2.

### **5.5.1 Communication Technology Conclusion**

The specification of the communication module is strongly related to the commercially available modems in the same or similar frequency bands. This enables the usage of widely-used RF-components for reasonable costs. Also the time until first prototypes for field tests will be available can be reduced significantly.

In Case of transmission errors an FEC-procedure or a CRC-procedure with a high retransmission rate are possible countermeasures. The design of a proper FEC requires investigations of the bit error behaviour of the radio channel. For the first step a CRC-procedure for very reliable error detection is proposed.



## 6. VEHICLE INTEGRATION

### 6.1 ON-BOARD SYSTEM ARCHITECTURE

Considering the logical architecture, the IVHW system may be divided into 4 parts:

- IVHW-Core
- GPS data source (simple GPS or more elaborated as navigation system)
- Communication module
- HMI module

This architecture is valid for OEM solutions as for retrofit solutions, some of the elements being or not already in place.

The physical architecture will depend on each manufacturer.

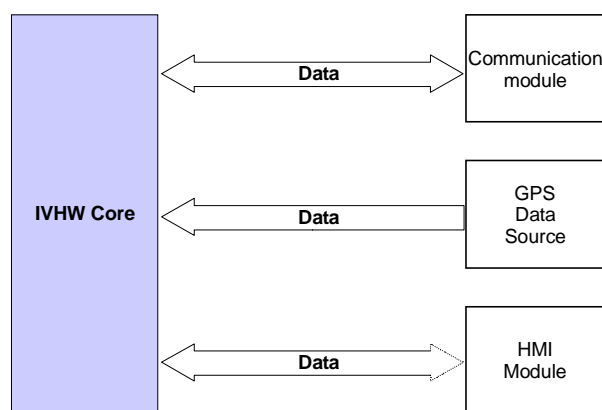

**Picture 6: system architecture**

The reasons for this separation are explained as follows.

1. IVHW requires only small resources of processing power, IO and memory. So, the IVHW-Core may be integrated into future infotainment systems sharing the resources of this system, e.g. display, CPU and memory, speech device, housing, connection to vehicle bus and GPS.
2. IVHW may present itself to the customer as an add-on of a system he already knows when integrated into navigation or infotainment systems. So, IVHW appears to be an embedded solution.
3. The communication device may be installed within the vehicle at any convenient place, for example nearby the GSM antenna.
4. As the transmitted data volume may grow for future system add-ons, a flexible architecture is necessary. The communication platform may be changed, the IVHW-Core remains to be the same.

#### 6.1.1 IVHW-Core

The modularity (IVHW-Core + communication module) provides flexibility for integration and extension of the IVHW-System. As the major advantage, the IVHW-Core is rather a software

implementation than a hardware implementation and therefore may be integrated into a infotainment system or navigation system. Of course, a stand-alone system may be realised.

The IVHW-Core is divided into 3 sections which do not represent hardware but different models of data and processing functions. The models are the foundation for a real IVHW-System in any suitable hardware.

### Section 1: Peripheral model

The peripheral model describes, which information has to be provided for the IVHW-System and which information is passed over to the peripheral systems (HMI, Communication module).

The peripheral model is a from the system's concept point of view a black box. Input and output information is abstract and not linked to any hardware restrictions. Information described in here is for example: GPS-Information Latitude and Longitude, received warning message, speed, airbag triggered, HMI information.

### Section 2: Data model

The data model describes, which data is processed within the IVHW-Core for internal processing steps.

This is not a definition of functions but a definition of what kind of internal information is generated and provided internally for the processing model. For example: A data structure with the elements: actual vehicle speed, actual GPS-Position, actual heading.

### Section 3: Process model

The process model describes internal IVHW-Algorithms and data flow to achieve the functionality of IVHW to be implemented in any programming language.

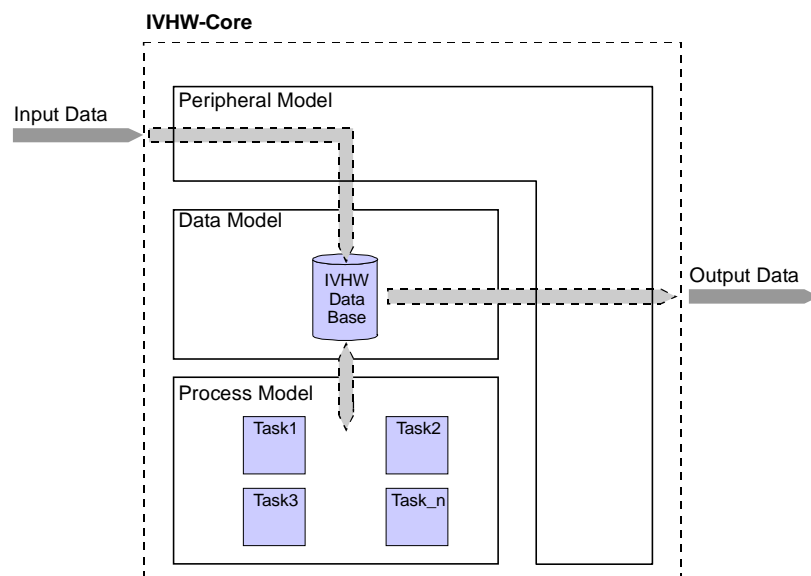

Picture 7: process model

With this concept, the integration of IVHW appears as follows:

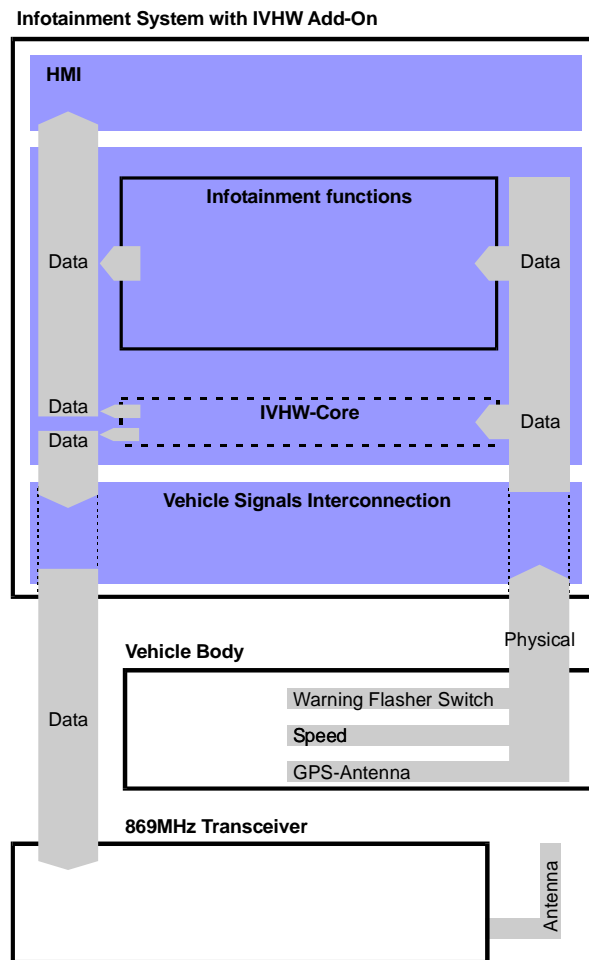

Picture 8: IVHW as Add-On

### 6.1.2 GPS Data Source

GPS-Information is necessary for

- Suppress received but not relevant warning messages
- Driver information about the geographic position of the hazard point

The GPS data source provides information of the geographic position of the vehicle only and is not related to any realisation in hardware.

### 6.1.3 Communication Device

The communication module is not a simple transceiver but a radio modem with an on-board microcontroller to release the IVHW-Core from different tasks. Therefore, the communication module acts autonomously.

### **6.1.3.1 Task: Data exchange with the IVHW-Core**

The communication device and the IVHW-Core are connected by a vehicle bus or conventional wiring. Data transfer between the IVHW-Core and the communication module will be carried out regarding:

- IVHW-Core -> Communication module: Warning message to be transmitted by the communication module
- Communication module -> IVHW-Core: Received warning message
- Optional: IVHW-Core -> Communication module: Configuration data for the communication module, for example maximum time gap for retry of message transmission.
- Optional: Communication module -> IVHW-Core: Status information, for example RF channel load.

It is recommended to hand over a new set of raw data from the core to the communication device each time a warning message shall be transmitted. This method clearly separates the tasks of the different layers according to the OSI-Model. It simplifies the handling of warning messages as the control remains by the core. If no more warning messages shall be sent, the core simply stops to hand over the raw warning message. As a draw-back, there will be no further message transmission, if the IHWM-Core has been destroyed by the accident with the communication module still being in order.

### **6.1.3.2 Task: Wireless data transmission**

After the warning message data has been channel coded (bit-coding and error protection) by the communication module, the further steps to transmit the (coded) warning message towards other vehicles will be processed autonomously by the communication module. No further action is necessary for the IVHW-Core.

### **6.1.3.3 Task: Wireless data reception**

The communication module samples the radio channel in order to detect a valid IVHW-Warning message. The IVHW-Core is not involved in this process. After any valid IVHW-Warning message has been received correctly, the data is decoded. The raw warning message will be handed over to the IVHW-Core for further processing. Any additional information for bit coding and error coding has been removed by the radio modem. The raw message appears to have the same content as the message which has been transmitted.

### **6.1.3.4 Task: Error coding**

The communication module gets the raw data of the warning message from the IVHW-Core and adds adequate error coding information before transmitting the warning message towards other vehicles. This concept simplifies the IVHW-System as the IVHW-Core is released from the error coding task. Also, the amount of transmitted data between the IVHW-Core and the communication module is limited to the raw data for the warning message.

### **6.1.3.5 Task: Error decoding**

After a warning message from another vehicle is received, the communication module decodes the message and the raw data of the warning message is handed over to the IVHW-Message.

### **6.1.3.6 Task: RF-Channel access**

Before transmitting a warning message, the communication module checks whether the radio channel is already allocated or not. Refer to 0.

# WP 2

## Impact Assessment and Evaluation

Document number:	ivhw_WP2_impact_assessment_final.doc	
Report number:	D 4.0	
Document version:	Issue 1	
Status:	Final	
Dissemination level:	INTERNAL IVHW Consortium French and German Authorities	
Date of preparation:	April 2003	
Authors:	Name	Organisation
Main authors	Michael Haumann	BASt
	Christhard Gelau	BASt
	Robert Schüssler	DaimlerChrysler
	Volker Entenmann	DaimlerChrysler
	Farida Saad	INRETS
	Vanessa Devarenne	INRETS
	Kate Littman	INRETS
Contributors	Martial Chevreuil	ISIS
	Sarah Paulin	ISIS



## List of Abbreviation

Abbreviation	Name	Unit	Resolution	Remarks
A	Acceleration	m/s <sup>2</sup>	0.1	Negative Values: Deceleration
AHD	Acknowledged Hazard Distance	m	1	Shown for 10s after pushing the AHD Button
AP	Accelerator Pedal	%	1	Continuous from 0 to 100 %
BAST	Federal Highway Research Institute	-	-	
BP	Brake Pedal	-	-	0: not pressed 1: pressed
DC	DaimlerChrysler AG	-	-	
DLV	Distance to Leading Vehicle	m	1	0: no vehicle detection
GHW	General Hazard Warning	-	-	
GPS	Global Positioning System	-	-	
HD	Hazard Distance	m	1	Positive: Sender in driving direction Negative: Sender behind driving direction
HT	Hazard Type	-	-	0: general hazard 1: breakdown 2: accident
HW	Hazard Warning	-	-	
HWF	Hazard Warning Flasher	-	-	
IVHW	Inter Vehicle Hazard Warning	-	-	
T	Timestamp	s	0.2	

TLV	Time to Leading Vehicle	s	0.1	TLV = DLV / V 0: no vehicle detection
TS	Touch Screen	-	-	
TW	Time related to Warning	s	0.2	WL = 0: time since last warning WL > 0: duration of warning
V	Velocity	km/h	1	
WL	Warning Level	-	-	0: no warning 2: warning
WTP	Willingness To Pay			



<b>1</b>	<b>EXECUTIVE SUMMARY .....</b>	<b>7</b>
<b>2</b>	<b>MOTORISTS' REACTIONS AT THE IVWH WARNING MESSAGE' RECEIVING .....</b>	<b>10</b>
2.1	METHOD .....	10
2.1.1	<i>Subjects.....</i>	<i>10</i>
2.1.2	<i>Demonstrator vehicle .....</i>	<i>11</i>
2.1.3	<i>Procedure .....</i>	<i>13</i>
2.1.3.1	Test route .....	13
2.1.3.2	Tasks during the test drives.....	14
2.1.3.3	Activation of the warning message .....	14
2.1.3.4	Hazard Distance .....	16
2.1.3.5	Visual display of the warning.....	17
2.1.3.6	Date recording.....	20
2.2	RESULTS .....	23
2.2.1	<i>Questionnaire data .....</i>	<i>23</i>
2.2.1.1	Simulated vs. expected events.....	23
2.2.1.2	Acceptance: Attitudes towards the system and willingness to pay.....	23
2.2.1.3	Summary of subjects' free comments .....	25
2.2.2	<i>Rationale of the analysis of hypothetical driver responses to warning messages .....</i>	<i>26</i>
2.2.3	<i>Analysis of subjects' viewing behaviour.....</i>	<i>27</i>
2.3	CONCLUSIONS.....	35
<b>3</b>	<b>SENDING A IVHW WARNING MESSAGE : STUDY OF MOTORIST'S BEHAVIOUR .....</b>	<b>37</b>
3.1	METHOD .....	37
3.1.1	<i>The interview guide .....</i>	<i>38</i>
3.1.2	<i>The motorists .....</i>	<i>41</i>
3.2	MAIN RESULTS.....	42
3.2.1	<i>Current use of hazard warning lights.....</i>	<i>42</i>
3.2.1.1	Context within which warning lights are used: functions of a different nature .....	42
3.2.1.2	Sending a warning message using hazard warning lights.....	43
3.2.1.3	Presence and proximity of approaching road users .....	47
3.2.1.4	Understanding the origin of the critical event and/or the sending of a warning message by another person. 48	
3.2.1.5	An alternative to the use of hazard warning lights: repeatedly pressing on the brake pedal.....	49
3.2.1.6	A limit to the use of hazard warning lights in an emergency situation: the location of the control button	50
3.2.2	<i>Motorists' reactions to the concept of a new warning system and a priori representations of the conditions of use. ....</i>	<i>51</i>
3.2.2.1	General assessment of the early warning concept proposed by the IVHW system. ....	51
3.2.2.2	Questions and remarks from motorists on the way the IVHW system works .....	51
3.2.2.3	A priori representations of the conditions under which the motorists would trigger the IVHW system ...	53

3.3	SUMMARY AND DISCUSSION ABOUT THE RESULTS .....	55
4	REFERENCES.....	57
5	ANNEXES .....	58

## 1 EXECUTIVE SUMMARY

The aim of the works that were realised in 2002 consisted to specify the drivers' representations and reactions to the new warning system. Two complementary approaches were implemented in this exploratory work:

- The first, developed by the BAST, examines motorist's reactions when they receive the warning messages issued by the new IVHW warning system
- The second, developed by INRETS, focuses on identifying the conditions under which motorists send a warning message. The exploratory study by INRETS aims firstly at analysing motorist's current representations and practices in the use of hazard warning lights as a warning and communication mode with others and secondly, to examine how and to what extent the new warning system would integrate with these practices.

### **The main results of BAST study obtained are the following:**

- After responding to a warning message subjects were asked which kind of event they would have expected in a real warning situation. As can be seen the event that was expected most frequently was a traffic congestion. The warning message "accident" corresponded most often with subjects' expectations. The warning message "breakdown" was correctly predicted in 50 % of the cases. A traffic congestion was expected nearly every time when the warning message "general hazard" was set.
- Acceptance: Attitudes towards the system and willingness to pay : To sum up, there seems to be a clear tendency for a positive attitude towards the system although one also should take care not to over-interpret this result for reason of the small sample size and the lack of reference values. Although „Willingness To Pay“ (WTP) seems to be restricted to the system as equipment of a new car the acceptable prices mentioned by the subjects seem to be pretty high. On mean the price subjects stated that they would pay for the system was 1.275,- € as additional equipment in a new car. But when interpreting this result one has to

keep in mind that an incomplete understanding of the systems functioning and/or “anchoring” effects might have biased subjects responses.

▪ Summary of subjects’ free comments:

The comments and explanations given by the subjects during the interviews at the turning point and after the test drives mainly referred to positioning of the display, the coding of the warning messages and experienced difficulties when receiving the messages. These can be summarised as follows:

- The display should be placed at another position maybe near the combi instruments in the cockpit.
- A differentiation of hazard classes should be implemented so that a classification of the danger is possible (maybe with different colours or by means of tone). The HW message was considered as unnecessary by the subjects because the combi-beep is judged to be sufficient to attract sufficiently high attention.
- Subjects explained that they would like to have a still better distinction between different hazard types (traffic congestion, accident, vehicle breakdown).
- A voice message is proposed to be added
- As a general result it turned out that subjects experienced severe difficulties when they had to convert the distance information. Especially when the warning time was short subjects were obviously overloaded when they tried to respond to both the hazard warning and the distance information.

**The main results of INRETS study obtained are the following:**

- For the majority of the motorists questioned, the use of hazard warning lights as a mode of communication and warning is a well-established practice. We note that the younger motorists declare that they acquired this approach through their training (and in reference to the Highway Code), whereas for a number of motorists, this approach has established itself over time on the basis of « social learning ». Only four of the motorists declare that they have not adopted this warning mode when driving.
- Depending on the context, on whether it is an urban or rural zone, the functions allocated to hazard warning lights are of a very different nature and clearly

demonstrate the advantage of distinguishing between the hazard warning light controls and those of the IVHW system.

- For the majority of the motorists interviewed, whether or not they use their hazard warning lights as a means of warning depends greatly on the nature of the road events that they are about to face ahead of them (accident, general slowing down or difficulty experienced by an individual driver and the variables that characterise them: proximity (spatial and/or in terms of time), magnitude, duration and the more or less predictable nature of the incident. Finally, it depends on the presence and proximity of the other users ahead. For half of the motorists questioned, there is an alternative warning and communication mode, in other words, repeated pressing on the brake pedal and it would seem that there is a certain amount of progressiveness in the warning value allocated to each mode. **Moreover, we have seen that, for certain motorists, the IVHW would in a way be a third warning mode, reserved for particularly critical road incidents.**
- **The majority of the motorists questioned approved of the early warning concept in the case of a critical road event as proposed by the IVHW system.** It is important, however to stress that the operating mode, at least as it was presented briefly in the presentation document, is not always fully understood by a number of motorists. It would be interesting in a future study to complete a more in-depth analysis of these representations insofar as they could play an important role in the use of the system.

## 2 MOTORISTS' REACTIONS AT THE IVHW WARNING MESSAGE' RECEIVING

This section describes the methods and the results of a study which was conducted by the Federal Highway Research Institute (BASt) in co-operation with the DaimlerChrysler AG (DC) within workpackage 2.5 in order to evaluate the IVHW system with respect to driver acceptance and impact on driver behaviour under conditions of a field test. As it is crucial for the effectiveness of the IVHW system that the warning messages are clearly and intuitively understood by the driver this study focused on driver responses to warning messages and their verbal attitudes towards the system. Generally, we expected that for drivers who are not familiar with the system a sufficient understanding of the system message could be demonstrated which should enable them to built up appropriate expectations about the oncoming hazard and to adjust their driving behaviour accordingly (see /1/ for a more detailed discussion). Because it was decided that driver behaviour should be observed when driving in real traffic for safety reasons no real hazards could be implemented and, of course, only hypothetical behaviours could be recorded.

### 2.1 Method

#### 2.1.1 Subjects

A sample of 12 drivers was recruited from the staff of the DaimlerChrysler AG, Esslingen. Six of the subjects were male, six female. In table 1 the most important characteristics of the sample are summarised.

Subject Nr.	Age	Gender	School Examina	Profession	Licence since years	Owned Car	Car owned since years:	Annual driven km
1	51	M	Secondary-school	Facilitator	33	Mercedes C220	1	27500
2	28	M	A-levels	Master of Business Administration	10	Golf 3	9	20000
3	22	F	A-levels	Student	6	Golf3 Cabrio	2	35000
4	36	M	A-levels	Clerk	14	Smart	3	15000
5	33	F	A-levels	Graduate in civil engineering	15	Mercedes SLK 200	1	15000

6	27	F	A-levels	Educationalist	9,5	None	0	10000
7	29	M	Advanced technical college certificate (Atcc)	Industrial Clerk	10	Mercedes C-Klasse Sport Coupe	1	13000
8	46	M	(Atcc)	Facilitator	28	A-Klasse	4	30000
9	43	F	A-levels	Promotor	24	Vaneo	2 Weeks	15000
10	30	F	A-levels	Employee responsible official	10	Corsa	3,5	27500
11	34	F	A-levels	Dipl. Bussiness Economist	27	Golf 3	6	25000
12	19	M	O-level	Industrial Clerk	1	Passat Variant	1	16500

Table 1: Sample characteristics

### 2.1.2 Demonstrator vehicle

As a demonstrator vehicle a Mercedes S-Class (see figure 1) was equipped with devices necessary measure relevant parameters of subjects' driving and viewing behaviour. Moreover, a simulation of the IVHW system including a prototype HMI were installed.



Figure 1: Demonstrator vehicle (Mercedes S-Class)

In figure 2, a simple illustration of the hardware architecture of the car is shown. A PC was build into the car boot. This PC was connected to the CAN-bus, the GPS receiver, a gyro, a display, two loudspeakers, and two video cameras. The speed, the velocity, the accelerator- and brake pedal angle, and the distance to the leading vehicle were read out from the CAN-bus. The GPS receiver and gyro data were used to get the exact position on the test-route. The display and the loudspeakers were used for visual and acoustical warning signals.

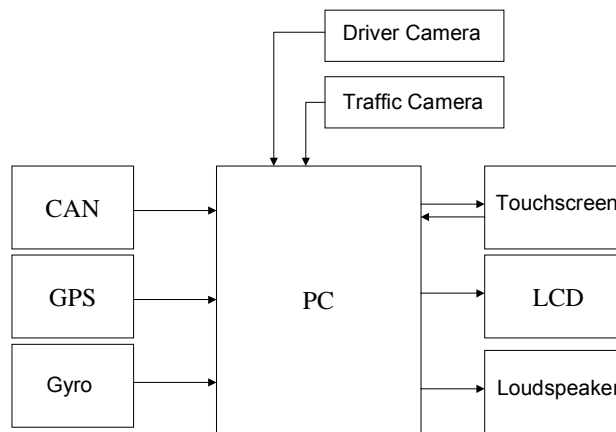

Figure 2: Hardware-Architecture



Figure 3: Touch Screen

The display was a VGA Touch Screen (TS) with a resolution of 800x600 pixels. The display was mounted at the right side of the dashboard (Figure 3) and it was used for driver input, too. The hatrack was used to mount the loudspeakers, which could be controlled independently of the normal sound system. Two video cameras were installed. One of them took a view of the road, the other one showed the driver. Frame-Grabber-Cards were used to connect the video cameras with the PC and to save the video data in a compressed form.



## 2.1.3 Procedure

### 2.1.3.1 Test route

Real danger situations released by other cars with a Warning-System (WS) could, of course, not be simulated in this test. Thus, the reception of the warning message was simulated on a fixed test route. Using the GPS navigation system, points for the warning messages were defined on the test route.

As a test route, a part of the highway A8 between Wendlingen and Merklingen in the German federal state Baden Württemberg (Figure 4) was chosen.



Figure 4: Testroute A8 between Wendlingen and Merklingen

The test procedure for each of the 12 test drivers was the following:

- 10 min explanations on demonstrator vehicle and WS
- 40 min driving the test route from Wendlingen to Merklingen
- break, interview
- 40 min driving the test route from Merklingen to Wendlingen
- interview

Four virtual senders were placed in each of the two driving directions. Each sender marked a virtual car with a transmitter standing at the defined GPS position. Different transmitter configurations were used for these senders. While the driver got acoustical and optical warnings the car and video data were stored on the harddisk of the PC. After the warning and his reaction the driver was interviewed by the accompanying test leader.

### *2.1.3.2 Tasks during the test drives*

Subjects were informed that during their drive along the test route a couple of hazard warnings would be presented. They were instructed to react or adapt their driving behaviour to these warning messages and, if possible, as they would react if these warnings were real. However, traffic safety was stressed to have the highest priority. Furthermore, subjects were requested to push a button on the touchscreen, when they expected that the point of hazard would have been reached under real conditions. After this “online”-estimation of the hypothetical position of the hazard was given subjects were asked to assess if had reacted in the same way under real conditions and to give comments if necessary. During the break, after the first half of the test route, and at the end of the test drive, interviews were continued and the subjects’ answers were recorded by the test leader. The complete questionnaire used for this study can be found in the annex.

### *2.1.3.3 Activation of the warning message*

Eight virtual senders were placed along the test route (four at each of the two driving sections). Each virtual sender simulated a car with the Hazard Warning Flasher (HWF) activated. The senders were configured according to the trigger criteria and the following three parameters:

- time of reception (early, late)
- transmission time (short, long)
- hazard type (general hazard, breakdown, accident)

To simulate an early or a late warning, two different threshold values were used for the minimum distance ( $d_{\min}$ ) and the time to sender ( $t_{\min}$ ) Table 2 shows these values.

Reception	Parameter $t_{\min}$	Parameter $d_{\min}$
Early	20s	400 m
Late	10s	300 m

Table 2: Parameters for time of reception

Looking for an effect related to the transmission time a “short” and a “long” transmission time (Table 3) were used in the simulation. The “short” transmission time was used for the „General Hazard Warning” (GHW) only, and was used to simulate the typical situation when a driver is driving against a traffic congestion using his HWF for a short time.

Transmission time	Sender message
short	For 5 s
long	Until sender is reached

Table 3: Transmission time

The last parameter to determine was the hazard type. It differed between three warning types (General Hazard, Breakdown, Accident). **Erreur ! Source du renvoi introuvable.** Table 4 shows which sender configuration was used for each of the simulated senders. The positions of the senders 1 to 4 were on the first half of the test route, the positions of the senders 5 to 8 on the second one. It was decided to place them with equal distances at road stretches where the driver has only limited preview on the course of the road.

Sender number	Reception	Transmission time	Hazard type
1	Early	Long	General Hazard
2	Late	Long	Accident
3	Early	short	General Hazard
4	Late	long	Breakdown
5	Late	short	General Hazard
6	Early	long	Breakdown
7	Early	long	Accident
8	Late	long	General Hazard

Table 4: Sender configuration

Now we have to differ between two function blocks. The first block is the “sender starts sending” block, and the other one is the “warning system sets warning message” block.

The simulated sender (first function block) started sending, when the trigger criteria defined to

- $t < t_{\min}$
- $d < d_{\min}$

was fulfilled. Here  $t$  is the time and  $d$  is the distance till the position of the sender may be reached. The warning message (second function block) was then presented to the driver when:

- $d < 1000\text{m}$  and sender was sending

#### 2.1.3.4 Hazard Distance

After a warning was displayed drivers had to indicate when they expected to reach the location of the hazard under real conditions by pressing an input button on the touchscreen (see figure 5). To minimise the chance of erroneous input the hazard

button was only activated when the warning message was displayed on the touchscreen. It was deactivated after use or 30 s after the warning was sent.

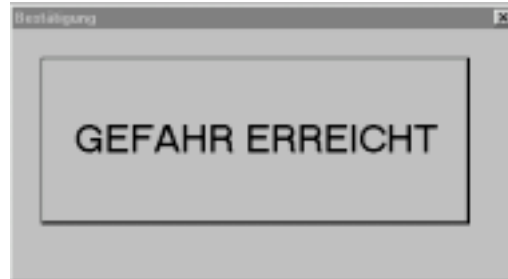

Figure 5 : Input button

### *Visual display of the warning*

The warning message was presented in the lower left corner of the display (Figure 6). The Command-Display had nearly the size of the illustration here.



Figure 6: Visual display of IVHW-Message and input button

Figure 7 shows the screen when no warning is given.

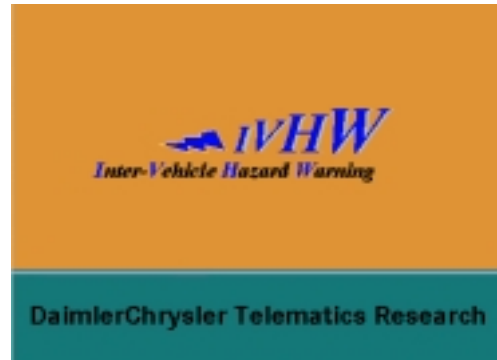

Figure 7: IVHW-Display „No Hazard“

The basic layout of the screen when displaying warning messages was as follows: The display consists of an upper and a lower text line with a pictogram between them. In the upper line the German word “Achtung!” (i.e. “Attention!”) was displayed. The lower line indicates the hazard distance in steps of 100 m. The distance was updated while the driver approached the virtual sender of the warning. Between the upper and the lower text line different hazard types were represented by different pictograms. The traffic sign symbol 1006-38 (traffic congestion) was used as a pictogram for the warning “General Hazard” because usually the warning “General Hazard” is transmitted by cars driving towards a traffic congestion. Examples of the display for the three different hazard types (“General Hazard”, “Breakdown”, “Accident”) are given in figures 8 to 10.



Figure 8: IVHW-Display for the hazard type „General Hazard“

Frequently a standing car with activated hazard warning flashers has a breakdown. Because there is no traffic sign symbolising this case a new one was defined which is shown in figure 9.



Figure 9: IVHW-Display for the hazard type "Breakdown"

Figure 10 shows the display for the "accident" warning message. Here the German traffic sign symbol No. 1006-36 was used.



Figure 10: IVHW-Display for the hazard type "Accident"

To attract the drivers attention, a short signal beep-sound was given at the moment when the warning message was displayed on the screen. This beep-sound is usually used for other warning and malfunction messages in the car too. For example when the fuel gets low or when the tank of the wiper washer gets empty.

The warning message was displayed for the time the sender was sending or until the position of the sender was reached.

### 2.1.3.6 Date recording

For the documentation of the driver actions and reactions on the different warning messages the parameters listed in Table 5, video pictures of the street and of the face of the driver were recorded. The data was recorded with a sampling rate of 200ms. For an easier analysis of the material the videopictures and the measured data was synchronised and fused in an mpeg videofile. Figure 11 shows a pic of this mpeg movie. At the bottom of the general view, a line with the recorded parameters, showing the current values, was displayed.

Parameter	Abbreviation	Unit	Resolution	Remarks
Timestamp	T	s	0.2	
Velocity	V	km/h	1	
Acceleration	A	m/s <sup>2</sup>	0.1	Negative Values: Deceleration
Accelerator pedal	AP	%	1	Continuous from 0 to 100 %
Brake pedal	BP	-	-	0: not pressed 1: pressed
Distance to leading vehicle	DLV	m	1	0: no vehicle detection
Time to leading vehicle	TLV	s	0.1	TLV = DLV / V 0: no vehicle detection
Warning Level	WL	-	-	0: no warning IVHW: 2: warning
Hazard type	Hat	-	-	0: general hazard 1: breakdown 2: accident



Hazard distance	HD	m	1	positive: Sender in driving direction negative: Sender behind driving direction
Acknowledged hazard distance	AHD	m	1	Shown for 10s after pushing the AHD Button
Time related to warning	TW	s	0.2	WL = 0: time since last warning WL > 0: duration of warning

Table 5: Measured parameters recorded with a sample rate of 200 ms

Another line appeared at the upper left corner, when a warning message was given. The whole picture data were compressed and saved in a 2 minute ring buffer. Thus, the example given in figure 11 tells us the actual time-scale (T=547,9), the vehicle speed (v=78 km/h), the velocity (a=0,3m/s<sup>2</sup>), the brake pedal use(not used=0; used=1), the distance to the leading vehicle (Distance Leading Vehicle (DLV) = 16m), the time to the leading vehicle (TLV=0,7 sec.), the warning level (WL=2; table 5), the Hazard Type (HT= 0; table 5), The Hazard Distance (HD= 425m), the Acknowledged Hazard Distance (AHD=...) and the time since the beginning of the warning (TW=0,3 sec.). Looking at the two pictures in figure 11 we can see that the driver is looking at the street (left picture), that there is a lot of traffic and that there is a car in front of our testing vehicle (right picture).



Figure 11: Videoframe

One minute after the warning message terminated the 2 minute ring buffer was automatically written to the harddisk. For identification after the test drive a special filename was created. Among others, the filename contains the current date, the time, and a sequence-number.

Simultaneously to the video data file a log file with the data of the two minute ring buffer was written to the harddisk. Figure 12 shows the log file data.

00864.7	133	-0.8	000	0	000	0.0	2	0	+0497	+0549	0006.0
00864.9	133	-0.8	000	0	000	0.0	2	0	+0489	+0549	0006.2
00865.1	133	-0.6	000	0	000	0.0	2	0	+0482	+0549	0006.4
00865.3	131	-0.9	000	0	083	2.3	2	0	+0474	+0549	0006.6
00865.5	131	-0.9	000	0	080	2.2	2	0	+0466	+0549	0006.8
00865.7	130	-0.9	000	0	000	0.0	2	0	+0459	+0549	0007.0
00865.9	130	-0.8	000	0	000	0.0	2	0	+0451	+0549	0007.2
00866.1	129	-0.9	000	0	073	2.0	2	0	+0443	+0549	0007.4
00866.3	129	-0.8	000	0	070	2.0	2	0	+0436	+0549	0007.6
00866.5	128	-0.8	000	0	068	1.9	2	0	+0428	+0549	0007.8
00866.7	127	-0.8	000	0	065	1.8	2	0	+0421	+0549	0008.0
00866.9	127	-0.9	000	0	064	1.8	2	0	+0413	+0549	0008.2
00867.1	126	-0.9	000	0	061	1.7	2	0	+0406	+0549	0008.4
00867.3	126	-0.9	000	0	058	1.7	2	0	+0399	+0549	0008.6
00867.5	125	-0.7	000	0	056	1.6	2	0	+0391	+0549	0008.8
00867.7	124	-0.9	000	0	054	1.6	2	0	+0384	+0549	0009.0
00867.9	124	-0.7	000	0	052	1.5	2	0	+0377	+0549	0009.2
00868.1	123	-0.8	000	0	049	1.4	2	0	+0369	+0549	0009.4
00868.3	122	-0.9	000	0	046	1.3	2	0	+0362	+0549	0009.6
00868.5	122	-0.8	000	0	044	1.3	2	0	+0355	+0549	0009.8
00868.7	121	-0.7	000	0	042	1.2	2	0	+0348	+0549	0010.0
00868.9	121	-0.8	000	0	040	1.2	2	0	+0341	+0549	0010.2

Figure 12: Extract from a log file

## 2.2 Results

### 2.2.1 Questionnaire data

#### 2.2.1.1 Simulated vs. expected events

After responding to a warning message subjects were asked which kind of event they would have expected in a real warning situation. Table 6 shows the comparison of actually simulated events and those events that were expected by the subjects. As can be seen the event that was expected most frequently was a traffic congestion. The warning message “accident” corresponded most often with subjects’ expectations. The warning message “breakdown” was correctly predicted in 50 % of the cases. A traffic congestion was expected nearly every time when the warning message “general hazard” was set.

		Expected event					
		Congestion	Breakdown	Accident	Unspecific hazard	Other	No prediction
Simulated event	General hazard	11				1	
	Accident	1		9	1	1	
	General hazard	11				0	1
	Breakdown	3	6			3	
	General hazard	12					
	Breakdown	3	7		1	1	
	Accident	3		9			
	General hazard	11				0	1
Total		55	13	18	2	6	2

Table 6: Comparison of simulated and expected events

#### 2.2.1.2 Acceptance: Attitudes towards the system and willingness to pay

After the test drives subjects were requested to answer some general questions concerning their attitudes towards the system adjustment and on their willingness to pay (WTP). Additionally, a German translation of a standardised questionnaire for the measurement of user acceptance [2] was administered. This questionnaire consists of nine items, which load on two scales, denoting the usefulness and users

satisfaction with the system under consideration. Subjects are required to give their assessments on five-point rating-scales ranging from -2 to +2. Items number 3,6 and 8 are mirrored. Referring to /2/ a overall score for usefulness was computed as the mean value of the items 1, 3, 5, 7 and 9. The satisfaction score was computed as the mean value of the items 2, 4, 6 and 8. The results are summarised in figures 13 and 14. To sum up, there seems to be a clear tendency for a positive attitude towards the system although one also should take care not to over-interpret this result for reason of the small sample size and the lack of reference values.

A high degree of acceptance can also be derived from the answers to questions referring to the „Willingness To Pay“ (WTP) (see table 7). Although WTP seems to be restricted to the system as equipment of a new car the acceptable prices mentioned by the subjects seem to be pretty high. On mean the price subjects stated that they would pay for the system was 1.275,- € as additional equipment in a new car. But when interpreting this result one has to keep in mind that an incomplete understanding of the systems functioning and/or “anchoring” effects might have biased subjects responses.

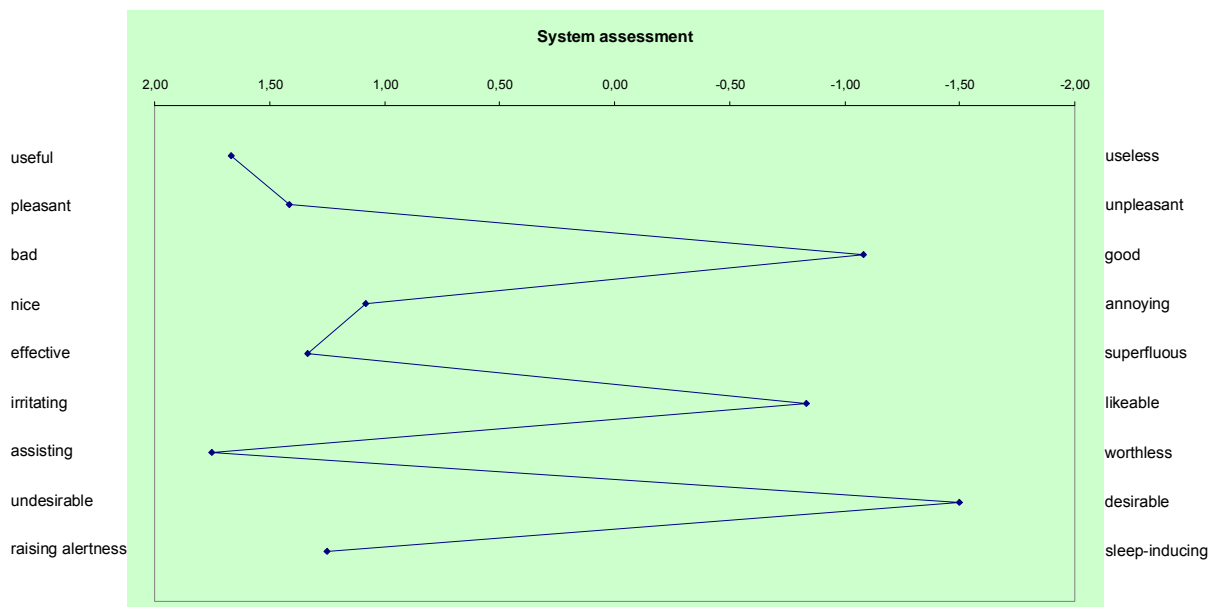

Figure 13: Assessment of system acceptance (rating-scales from 2 to -2)

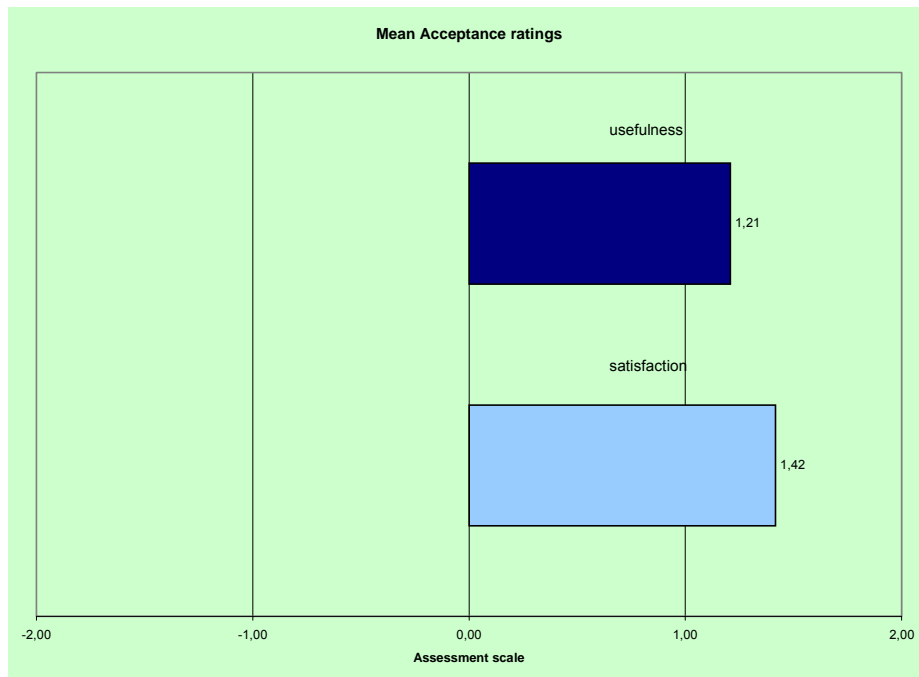

Figure 14 Mean acceptance ratings on the scales “usefulness” and “satisfaction”

	Yes	No	Euro
Would you upgrade your car with this system?		12	
Would you buy this system as additional equipment in a new car?	9	3	
Do you think this system could be a suggestive standard equipment?	8	4	
Upgrade with warningsystem			%
Additional Equipment			1275 Average
Additional Equipment			1250 Median

Table 7: Frequencies of responses on questions concerning WTP

### 2.2.1.3 Summary of subjects’ free comments

The comments and explanations given by the subjects during the interviews at the turning point and after the test drives mainly referred to positioning of the display, the

coding of the warning messages and experienced difficulties when receiving the messages. These can be summarised as follows<sup>1</sup>:

- The display should be placed at another position maybe near the combi instruments in the cockpit.
- A differentiation of hazard classes should be implemented so that a classification of the danger is possible (maybe with different colours or by means of tone).
- The HW message was considered as unnecessary by the subjects because the combi-beep is judged to be sufficient to attract sufficiently high attention.
- Subjects explained that they would like to have a still better distinction between different hazard types (traffic congestion, accident, vehicle breakdown).
- A voice message is proposed to be added
- As a general result it turned out that subjects experienced severe difficulties when they had to convert the distance information. Especially when the warning time was short subjects were obviously overloaded when they tried to respond to both the hazard warning and the distance information.

### **2.2.2 Rationale of the analysis of hypothetical driver responses to warning messages**

Because the analysis of the video data and the car data had to rely on hypothetical driver behaviour it was necessary to select or “filter out” at least those scenarios, i.e. responses to warning which were obviously artificial and could clearly not be expected to represent driver behaviour under conditions of real traffic. This selection was done on the basis of drivers’ immediate self-evaluations of their responses to the warning. Taken together subjects explained for a total of 47 scenarios that their behaviours corresponded with those under conditions of real traffic. For the remaining 49 scenarios they explained that they would respond in some different way under conditions of real traffic.

---

<sup>1</sup> A complete listing of all statement which were recorded by the test leader can be found in the Annex I.

In the following paragraph these two types of scenarios will be briefly compared with respect to parameters of velocity and deceleration. The detailed analysis of driver responses will then focus on those 47 scenarios which can be assumed to reflect driver behaviour under conditions of real traffic.

With the arriving of the warning message and exactly 5 sec. later the speed and the velocity were read out of the data files and analysed.

### 2.2.3 Analysis of subjects' viewing behaviour

As a final step of the data analysis the video sequences of subjects' viewing behaviour during the warning scenarios were considered. The video-films were analysed frame by frame starting at time the warning message was displayed and ending with the pressing of the AHD button. The analysis was done by counting the time the driver spent looking into one of the following pre-defined areas:

- Street
- Display
- Other directions

More specifically, the parameters of subjects' viewing behaviour were calculated according to the following procedure: As the duration of single glances ( $t_{glance_{x,y,z}}$ ) and the frequency ( $h_{glance_{x,y,z}}$ ) of glances to the road, to the display and into other directions had to be determined the viewing direction was observed from frame to frame and in case of a change of the direction the time ( $t_{1start_{x,y,z}}$ ) was saved. Because of the low sampling rate "dwell times" had to be neglected. After the next change of the viewing direction the value ( $t_{1stop_{x,y,z}}$ ) was saved. The parameter x is the number of the test-drive (1-12), the parameter y is the warning situation (1-8) and parameter z is the direction of the view (1=Street, 2=Display, 3=other).

The duration of a single glance is then the difference of the parameters ( $t_{duration_{x,y,z}} = t_{1stop_{x,y,z}} - t_{1start_{x,y,z}}$ ) on the time-scale. The maximum temporal resolution was  $t_{resolution} = 0,2s$ , and the sampling rate  $f_{measure} = 5Hz$ .

Analysed were  $n = 12$  test drives with  $w = 8$  warning messages in each test drive.

Because of the irregular assessment of the AHD (figure 27) the times were oriented on the whole AHD time and the frequency was oriented on the whole frequency in the AHD time. The values were shown in percent.

Regarding to the single results the variance  $\sigma^2$ , the standard deviation  $\sigma$  and the standard error of mean  $S_F = \frac{\sigma}{\sqrt{n}}$  were calculated and the times and frequencies,

written in percent, were averaged over the 12 test drives. A t-test for dependent samples was used to check the significance with  $\alpha = 5\%$ .

Figure 23 shows an example for the values of the AHD assessed by the test drivers. It can be seen that the values are spreading in a wide area.

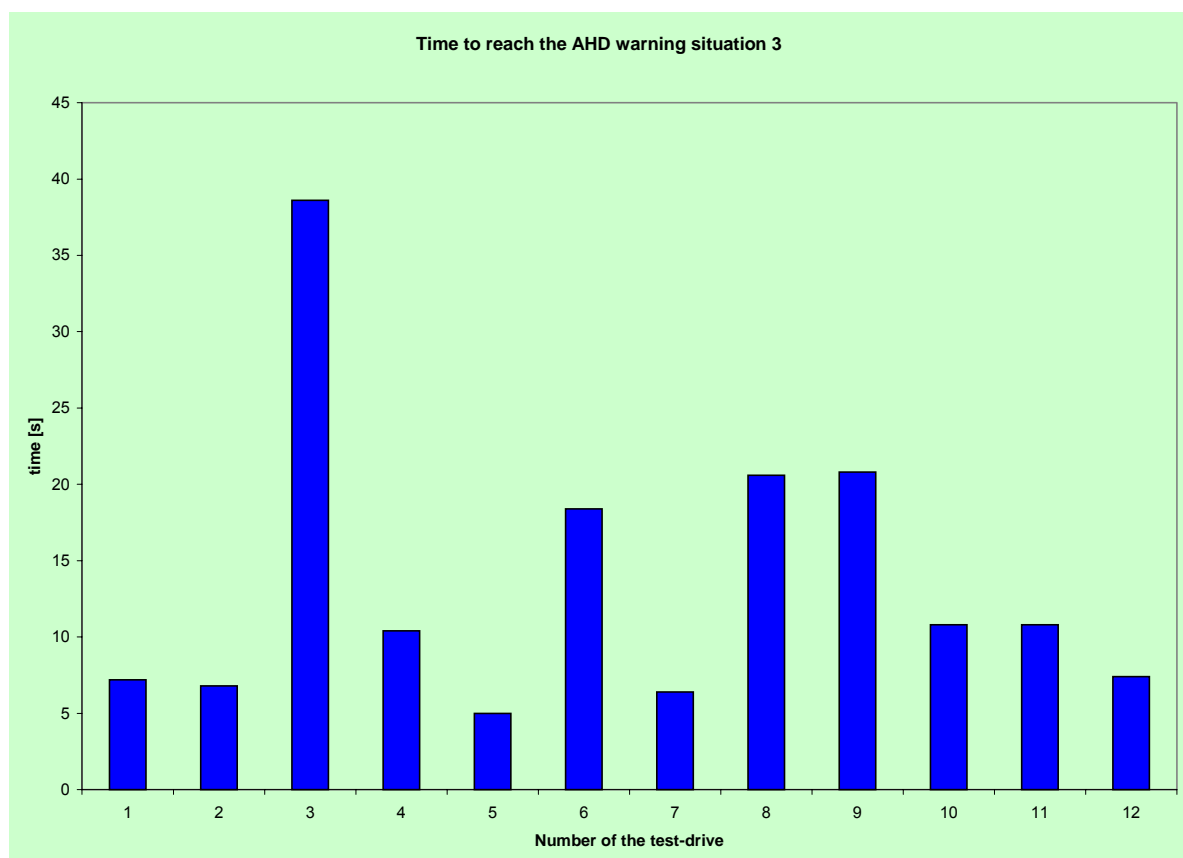

Figure 23

*Illustration of the time to reach the AHD for warning situation 3*



Figures 24-26 show the mean times spent for viewing at the display, the road and other directions. These diagrams cannot be used for an prediction, because of the big variation of the AHD time frame in each warning situation (Figure 23). That means, someone who has twice as much time as another, could do twice as much view changes.

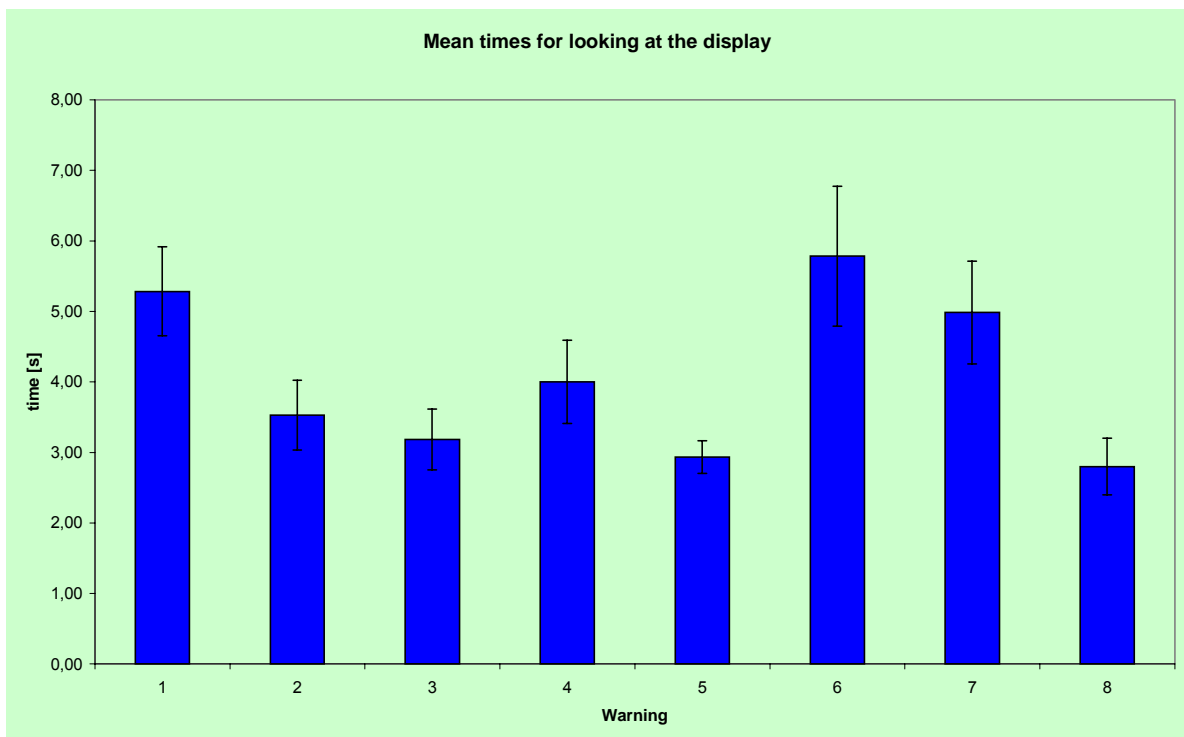

Figure 24 Mean times spent viewing at the display across the eight warning situations

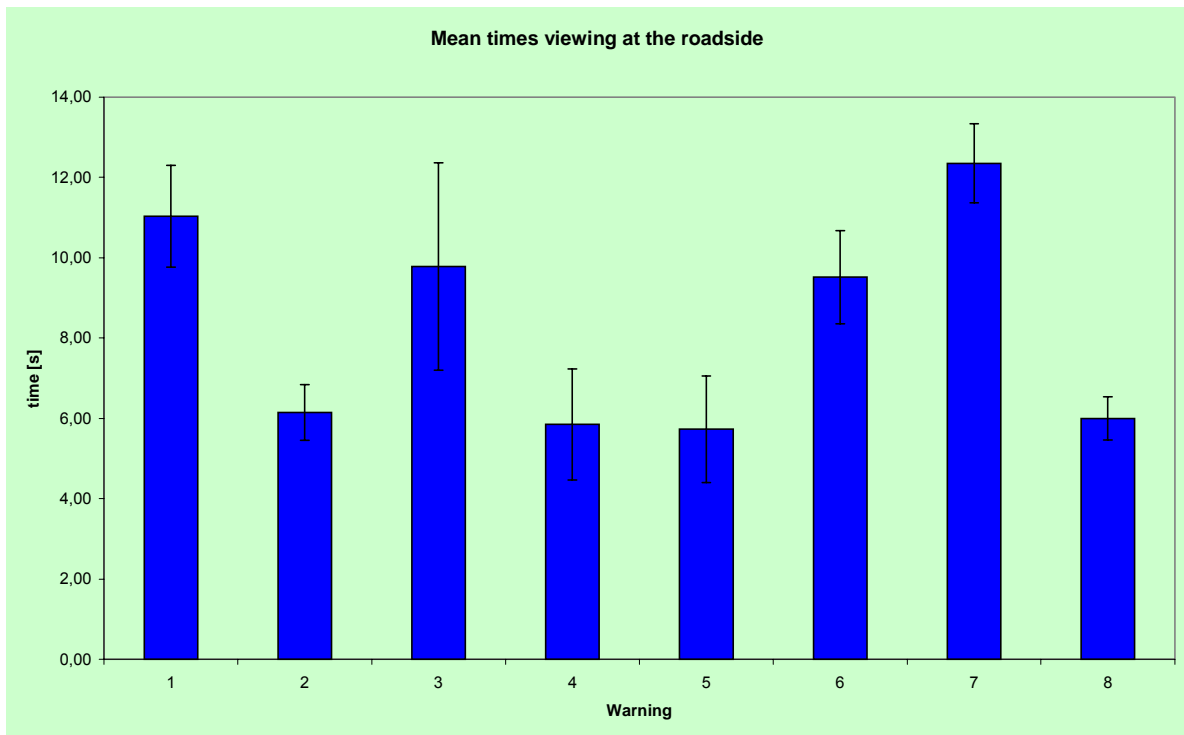

Figure 25 Mean times spent viewing the road

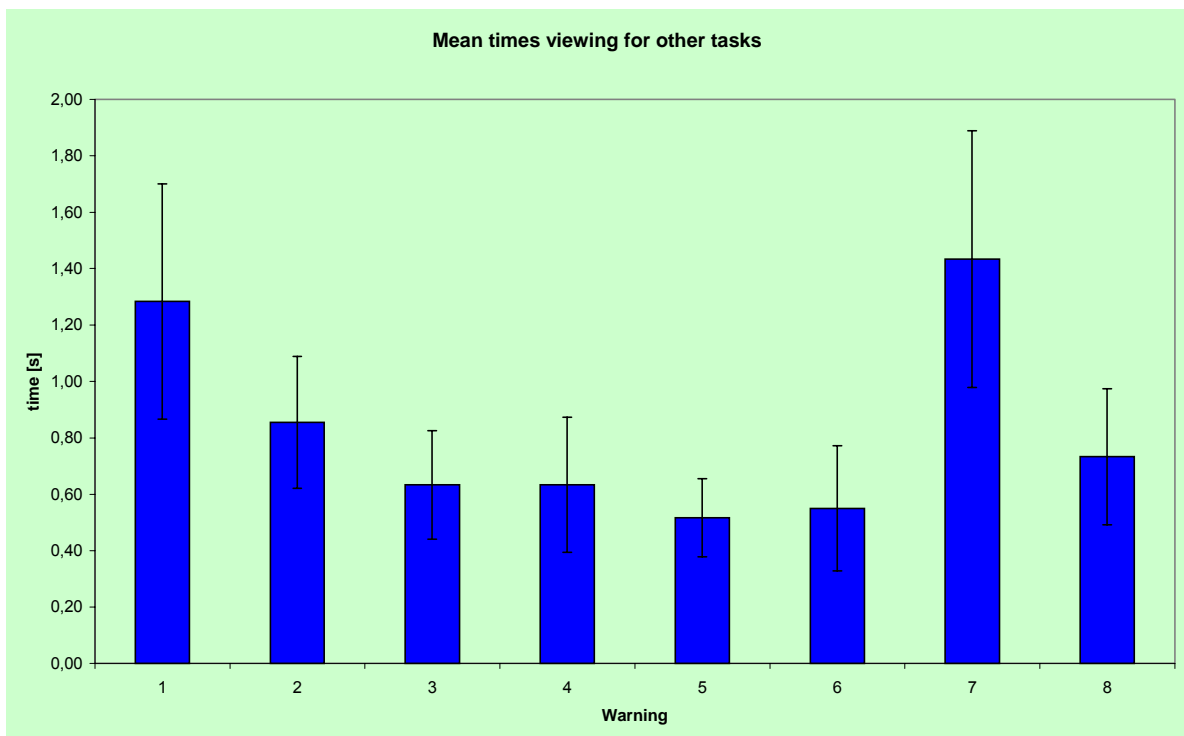

Figure 26 Mean times spent for viewing at other directions

Figure 27 shows the mean percentage of time spent for viewing to the display. It can be seen, that about 30 % of the times subjects spent for looking at the display. But it should be taken into account, that the display was used as a touch-screen-knob too.

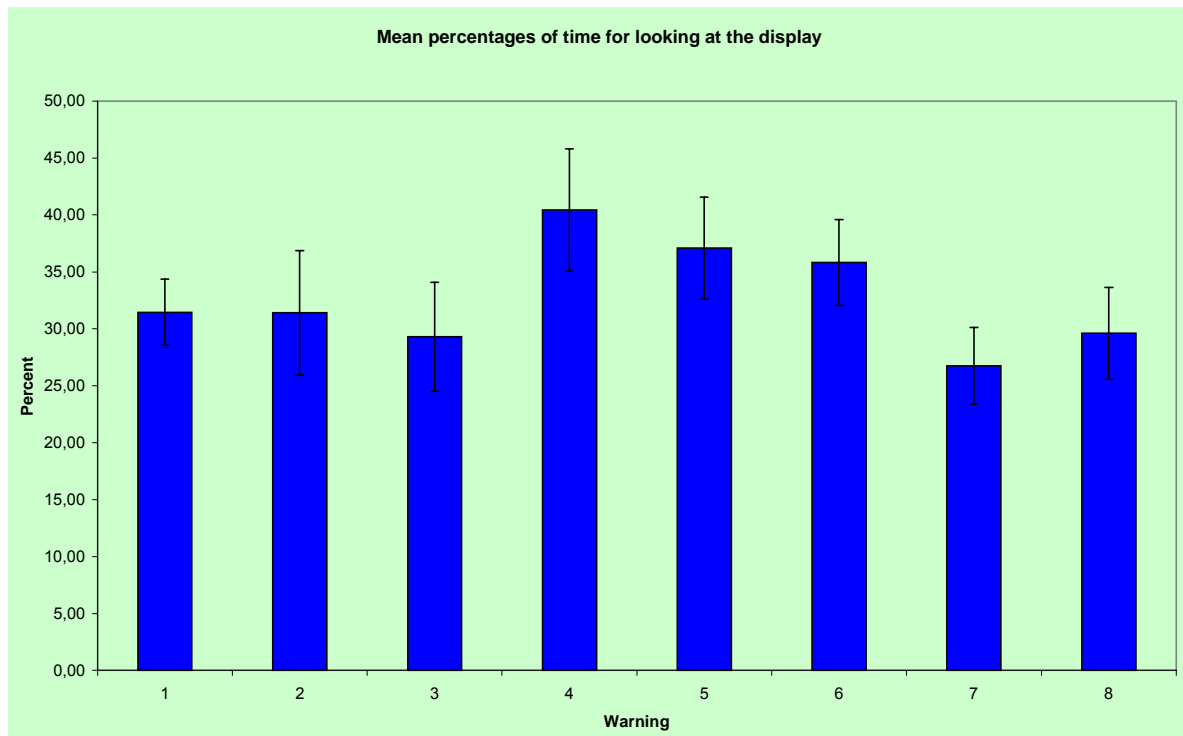

Figure 27 Mean percentages of time spent viewing at the display

Figure 28 shows the mean percentage of time spent for viewing at the roadside. It can be seen here that these time vary between 52% and 66%.

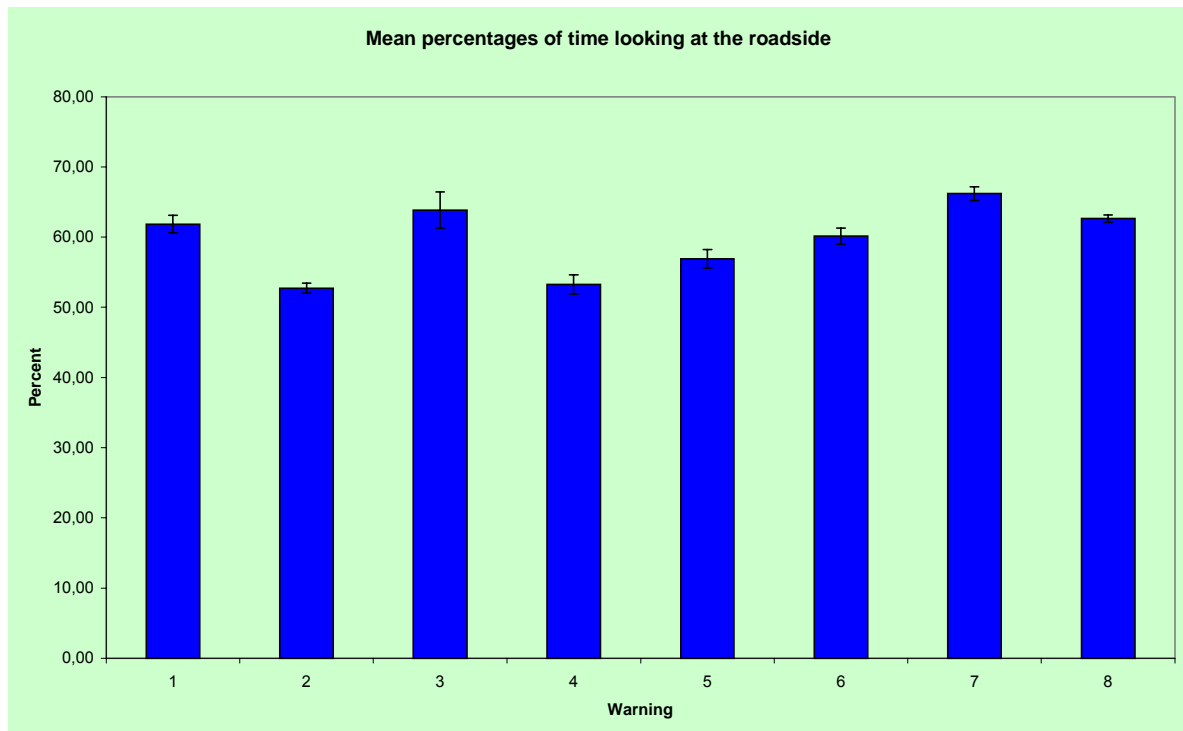

Figure 28 Mean percentages of time for “street view”

Figure 29 shows the percentage of time that was used for “other” views. There was not much time used for other viewing directions. The values varied between 4 % and 7.5% and the standard error of mean was high.

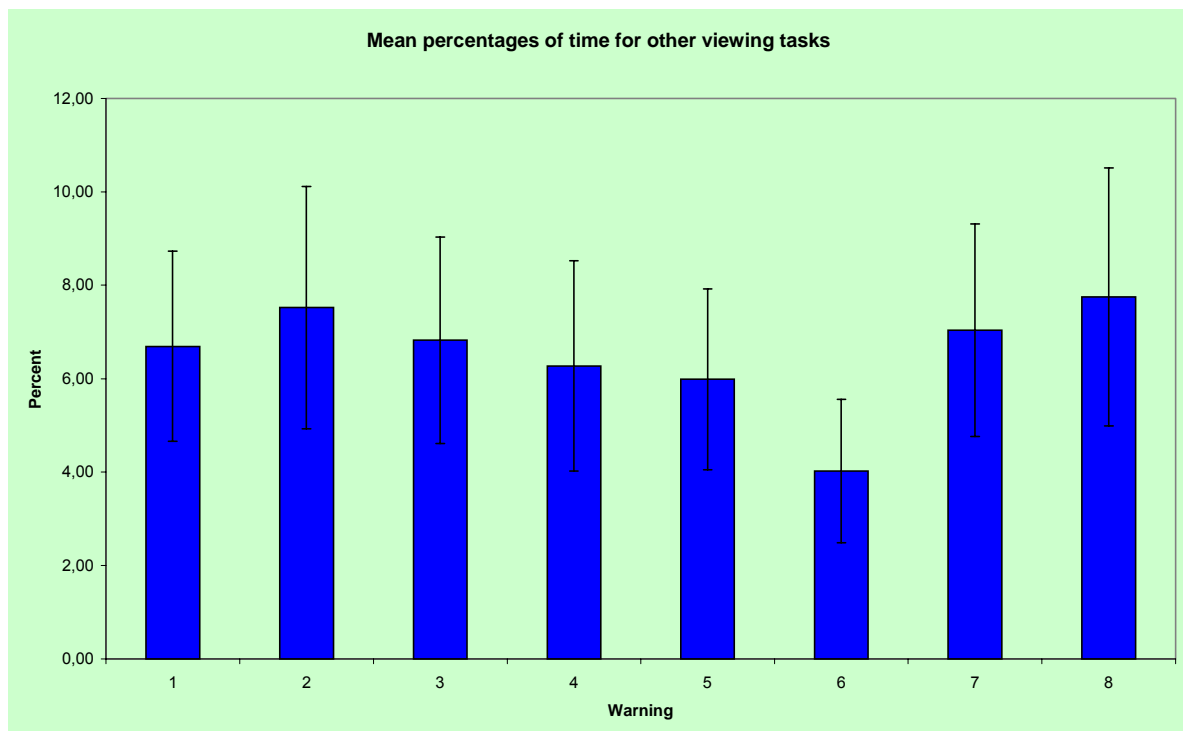

Figure 29 Mean percentage of time for “other view’s”

Figure 30 shows the percentages of the frequency for the view to the “Display”. 30% up to 40% of the overall time were used to look at the display. A special effect in one of the warning situations could not be seen here.

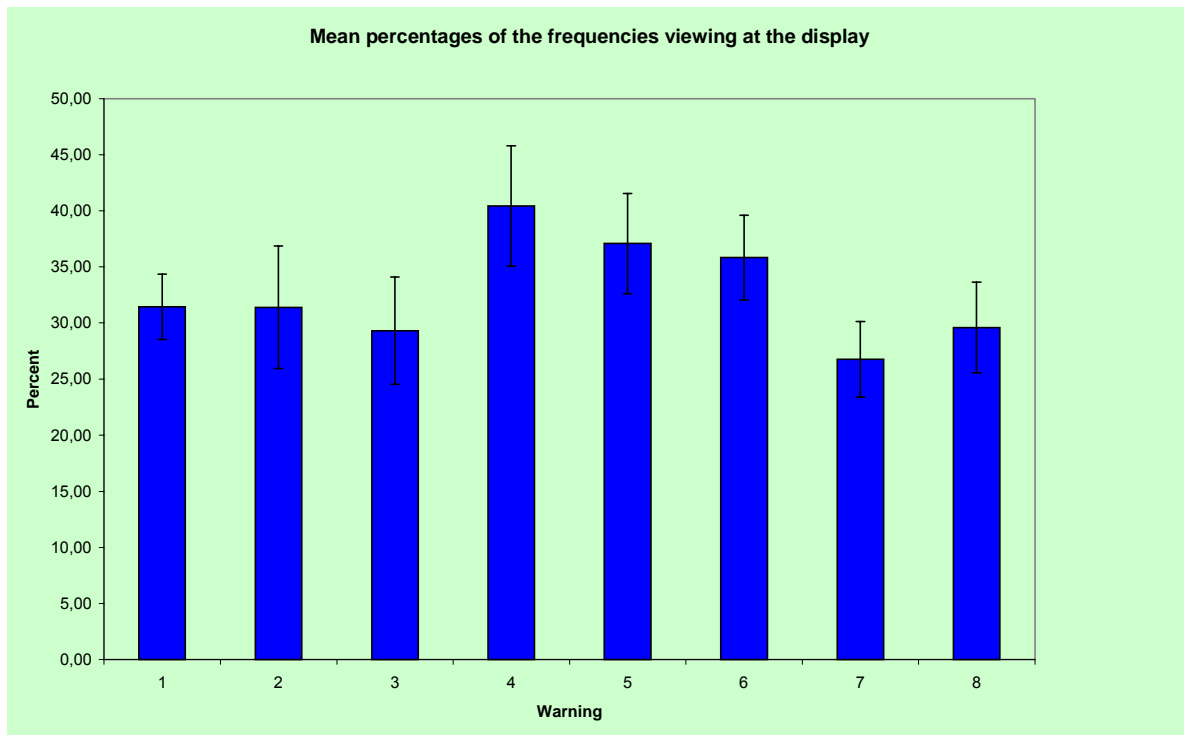

Figure 30 Mean percentage of the frequency changing the view to the “display”

Figure 31 shows the percentages of the frequency for changing the view to the “street”. There seems to be a steady level of frequency around the 50 % marker. A special effect on some warning messages couldn’t be seen.

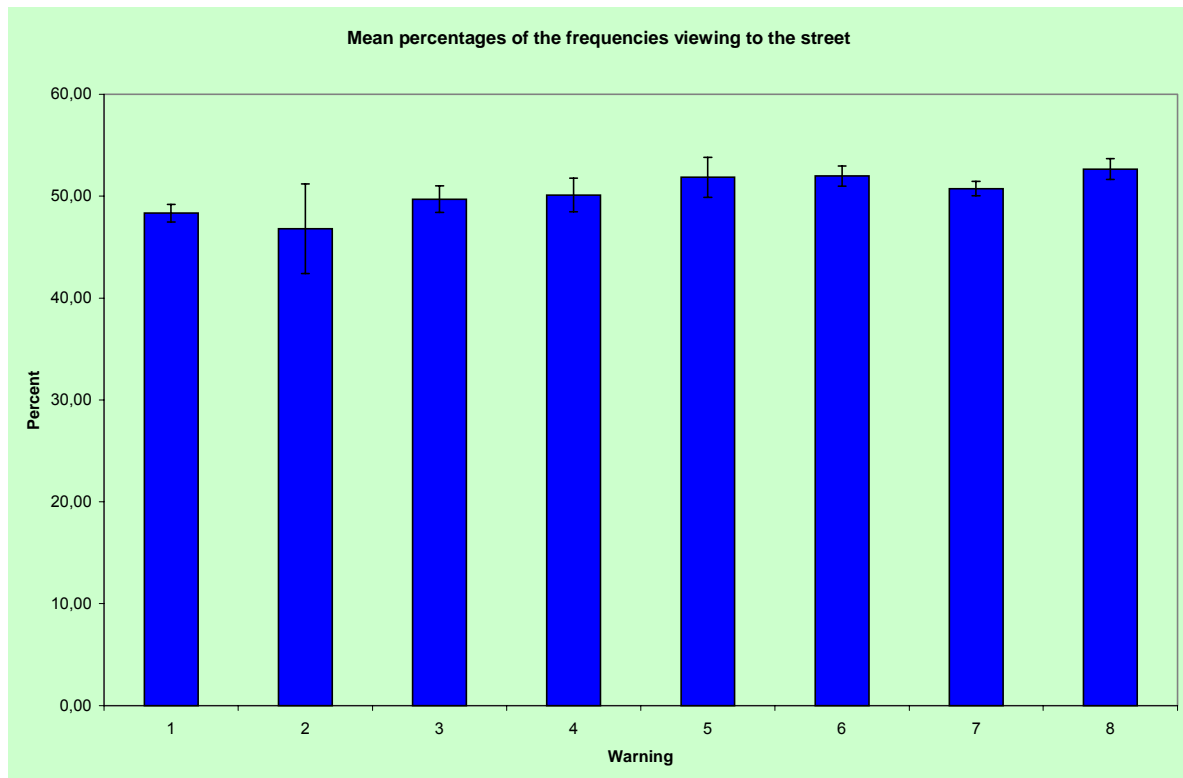

Figure 31 Mean percentage of the frequencies changing the view to “street”

The mean percentage of the frequencies changing the view to “other” is shown in figure 32. The values vary between 5% and 12 % and the standard error of mean is very high.

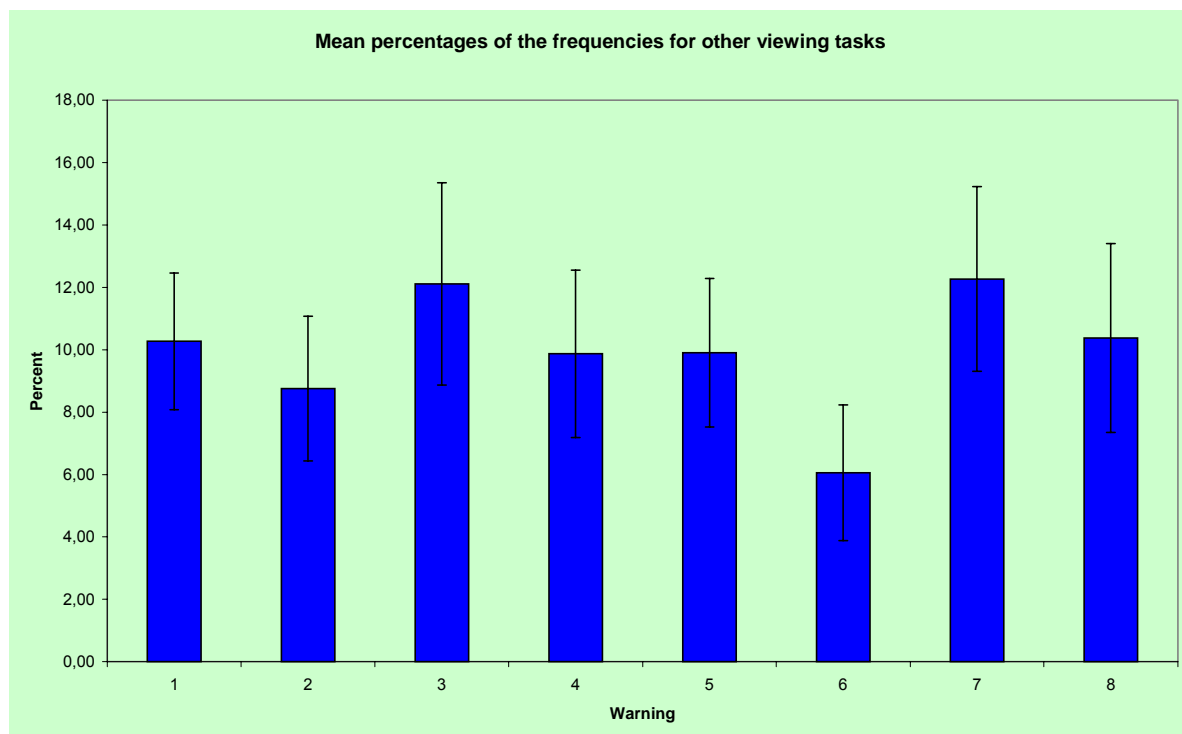

Figure 32 Mean percentage of the frequency of changing the view to “other” directions

## 2.3 Conclusions

The analysis had to be based on hypothetical behaviour because of practical restrictions. So one of the basic points during this analysis was to show that the methodical procedure was adequate. The comparison of relevant parameters of the driver behaviour in the two situations “real behaviour” and “no real behaviour” showed us, that the behaviour of the drivers in real situations could be approximated. So the validity of our results should be given. The consistent speed differences in case of “real behaviour” compared with the not systematically differences in case of “no real behaviour” showed this very clearly.

The results for the user acceptance were very positive and gave us a reference parameter for the analysis of the behaviour in further driver tests. Looking at the methodical point of view a better information of the test-drivers about the system concept should be realised.

Comparing the anticipated hazard with the real contents of the hazard warning there is room for improvement for the warning messages. Especially the “hazard warning”

and the “breakdown” warning message weren’t that clear for the drivers. The suggestions made by the drivers show this in an impressive way.

Different warning messages should lead to an adequate reaction. This reaction should be implemented by an explicit displayed warning message to make it easier to understand for the driver.



### **3 SENDING A IVHW WARNING MESSAGE : STUDY OF MOTORIST'S BEHAVIOUR**

We have already seen above that the driver plays a major role in activating the IVHW system and that this activation is coupled with the triggering of the vehicle's hazard warning lights. Moreover, two typical situations for IVHW system activation represent possible areas for extending the functions currently allotted to hazard warning lights (indication of a vehicle on the hard shoulder for emergency use and the presence of « dangers » on the road).

The exploratory study carried out by INRETS aims firstly at analysing motorists' current representations and practices in the use of hazard warning lights as a warning and communication mode with other users and secondly, to examine how and to what extent the new warning system would integrate with these practices.

More precisely, it aims at highlighting:

- the contexts in which motorists use their hazard warning lights;
- their representation of the current functions of hazard warning lights;
- the variables that determine their usage, in particular when driving on the motorway and on urban expressways;
- and finally, their a priori representations of the new warning functions proposed by the IVHW system.

#### **3.1 Method**

We have very little information on motorists' current habits in the use of hazard warning lights.

Given the deadlines and resources allocated to the study, it was not possible to observe real-life driving situations and motorists' use of hazard warning lights (rarity of events likely to incite them to use their hazard warning lights) nor was it possible to complete a study on a driving simulator (problems in terms of the cost and IT development times required in order to carry out such a study).

An exploratory study was therefore carried out on the basis of semi-directive interviews with twenty motorists. The results of this study should provide a useful basis for future, more systematic investigations.

### 3.1.1 The interview guide

The interview guide was set out based on the analysis of four preliminary interviews and includes two main parts (see heading n° 1, the interview guide) :

- the first part focuses on current use of hazard warning lights, the context within which they are used, how useful they are perceived to be and reactions to hazard warning lights used by other motorists, etc.
- the second part presents the concept of the IVHW system to motorists (see heading n° 2, explanatory notice) and aims to capture their understanding of the utility of this new system and the potential context for its usage.

The interviews lasted between 30 minutes and one hour and were recorded on a tape recorder and were then retranscribed for analysis.

#### Heading 1 : The interview guide

##### Presentation of the study

We are working on a project for the design of an on board warning system for cars. This system will make it possible to send and receive warning and danger messages to and from other motorists based on the hazard warning lights already installed in cars. Later on we will present this system to you in detail. Before doing so we would like to discuss the way you currently use your hazard warning lights on a day to day basis.

##### First part of the interview

Based on your experience, and in particular, based on your experience over the last year, can you tell me whether in your everyday experience of driving you use your hazard warning lights?

- If so, try to make the driver to describe in as detailed a manner as possible the situation/s in which he used them:
  - the event that led him to use the hazard warning lights;
  - the context in which he used them: in town, on a main road, on the motorway, etc.
  - the importance and utility of using them in this context.

In the situations that you have described, do you always think to use them ?

Are there other situations where you think it is important or useful to use your hazard warning

lights?

- If not try to make the driver to explain why: never been in a situation that justified their usage, use of another mode of communication, etc.

Based on your experience, can you remember having been in one or several situations where the motorists ahead of you lit their hazard warning lights?

- If so, try and get the person to describe the situation/s where they used them in as detailed a manner as possible.

How did you react ?

Is it always easy to understand why the driver in front puts his/her hazard warning lights on ?

Did you also put your hazard warning lights on or did you use another method ?

In your car or in the car that you usually drive, can you tell me where the signal warning light button is?

### **Second part of the interview**

I am now going to present System X that is currently being developed in more detail (give explanatory notice to read). Please feel free to ask any questions you have if you wish for further information.

Can you summarise the system and how it is used, in the same way you would if you had to explain it to someone who wasn't yet familiar with it?

In your opinion, what is the main advantage of such a system?

## **Heading 2 : Warning system X - Explanatory Notice**

### **What is it used for?**

Numerous accidents are caused by the difficulty motorists have in evaluating a dangerous situation ahead of them under certain circumstances. This difficulty can be due to the wrong kind of driving in a given situation and in particular, to excessive speed. It can also be caused by poor visibility or momentary masking of the road ahead.

System X was developed in order to help motorists anticipate and adapt their driving to unexpected events such as accidents and a tailback. Thus, the system could help reduce the risk of collision.

System X is a warning system fitted on board the vehicle that sends and receives warning messages or messages to warn of a danger from one neighbouring driver to another. It makes it possible to warn motorists who are approaching an area where there is a risk and also enables motorists to be warned by other motorists who have already reached the danger zone.

System X improves driver safety and relies on a person's sense of responsibility given the fact

that those motorists whose vehicles are equipped with the system become interdependent.

#### **How does it work?**

With this type of system, a driver who notices a dangerous situation can send a warning message to the motorists behind him/her. He can also receive a warning message from the motorists ahead. In the case of an accident, a warning message is sent out automatically as soon as the airbag is triggered. In all cases, when a warning message is sent, the hazard warning lights are activated.

System X has a transmission range of 1000 m. In other words, those motorists who are equipped with the system and who are up to 1000 m behind the vehicle that transmits the message receive the warning message. Messages are sent using radio waves (band width 869.4-869.65 Mhz).

#### **When is this system used?**

System X is used under the same circumstances as hazard warning lights, in other words when the driver considers that the situation ahead is risky and could become dangerous. For example, a tailback can be a sign of danger. Vehicles that have been in an accident and have stopped sideways on along the road are a serious incident and a warning message sent out using System X would considerably limit the risk of an additional accident since those motorists who were warned earlier would have more time to anticipate and adapt their speed. A vehicle that has broken down on the hard shoulder would also activate the System X warning message for its security and that of its fellow road users.

#### **How does one send a warning message?**

To send a warning message, the driver of the vehicle presses the warning button or another specific button. As System X is linked up to the hazard warning system, the same button triggers both the sending of a message and the hazard warning lights. When the motorist wishes to stop sending the message, he or she presses on the same button once again. An alarm sounds and/or a visual warning is given (for example displayed on a screen) when the warning message is received from another driver. The information contained within the message can concern the place, the distance that separates the driver from the danger and possibly even the nature of the danger. It is the system that automatically determines the contents of the information sent. The driver who receives the warning signal is therefore warned of a danger further ahead and can quickly take action and adapt his driving to the circumstances. He can also, if the circumstances allow and require him to, send another warning message to motorists who are approaching the same destination behind him.

### 3.1.2 The motorists

Twenty motorists took part in the study. The drivers were selected according to four main criteria: age, sex, their global driving experience and the seniority of their driving licence. The motorists' characteristics are described in the following tables.

All the motorists are regular drivers (several times a week) or daily drivers. We note, however, that women use the motorways and expressways less frequently than men.

	Sex	Female	Male	Total
Age				
≤25		2	2	4
26-35		5	5	10
>35		3	3	6
Total		10	10	20

	Sex	Female	Male	Total
Seniority of driving licence (years)				
≤2		1	1	2
3-10		4	5	9
>10		5	4	9
Total		10	10	20

	Sex	Female	Male	Total
How often the person drives				
Daily		7	6	13
Regularly		3	4	7
Total		10	10	20

	Sex	Female	Male	Total
Annual mileage				
<10000		6	2	8
>10000		4	8	12
Total		10	10	20

Sex	Female	Male	Total
Motorways/expressways			
Frequent (several times a week)	1	4	5
Regular (once a week)	3	3	6
Occasional (once a month or less)	6	3	9
Total	10	10	20

## 3.2 Main results

Through the analysis of the interviews, we first of all specified the contexts within which motorists currently use their hazard warning lights and went on to identify the main variables that determine whether or not they send a warning message on motorways and expressways. (IV.1.).

In the second part, we examine motorists' reactions to the concept of a new warning system and attempt to specify the a priori representations of the conditions under which they could use such a system (IV.2).

In the third and last part, we propose a summary and a discussion on the results and attempt to draw research guidelines from these in order to validate the results obtained in this exploratory study. (IV.3).

### 3.2.1 Current use of hazard warning lights

#### 3.2.1.1 Context within which warning lights are used: functions of a different nature

Out of the twenty motorists interviewed, sixteen declare that they use their warning lights on the motorway or on the expressway (ring road and more occasionally, on trunk roads) and nineteen declare that they use them in urban areas.

The functions associated with the use of hazard warning lights differ according to the road context: motorways and expressways on the one hand and urban areas on the other.

On motorways and expressways, the use of hazard warning lights is strongly associated with the notion of danger, when a critical road event takes place, i.e., one

that is likely to have an impact on individual or collective safety. In most of the cases described by motorists it is a question of indicating a danger linked to the general traffic conditions (rapid deceleration, an accident, a traffic jam, etc.) or of indicating a danger that is specifically related to a given driver (broken down vehicle or vehicle at a standstill on the hard shoulder). The warning functions associated with these cases are therefore very close to the formal functions of use as provided for by the Highway Code.

In urban areas, the use of hazard warning lights has a totally different function and aims at indicating a short-term problem caused by a car that has stopped on the road (double parking) or in a forbidden place (garage exit). Their usage in this context is most often associated with a momentary transgression of formal rules (and corresponds to a request for tolerance in relation to this transgression).

*"I use them when I'm double-parked in a street when I'm going to buy something quick».*

*"Well, more often than not, in fact, its when I park in an unauthorised place, but not for very long, so I put my hazard warning lights on to show... if ever a policeman passes by, that in fact the car is parked, but only for a very short space of time".*

These uses that differ greatly from those mentioned above clearly illustrate the advantage of having two separate control buttons for the IVHW system and the hazard warning lights.

Moreover, one would note that several motorists say that they use, or have seen others use, their warning lights in contexts and for communication purposes that have little to do with their initial intended function: hello between friends or thanks to another road user who has made it easier for them to get back in lane for example.

*"When several cars are travelling together... for example when we split up, we say "goodbye" by pressing on the hazard warning lights button, just two quick presses, its pretty good because it can be seen from behind and from the front too"*

### 3.2.1.2 Sending a warning message using hazard warning lights

As stated above, four motorists out of 20 (three women and a man) declare that they never use their hazard warning lights on motorways and expressways. These motorists have not got into the habit of using this warning and communication mode

and one of them considers that hazard warning lights « *were not designed for this purpose* ». For the same aforementioned driver, the lights should only be used to indicate that the vehicle has stopped due to a breakdown and represents exactly the same function as the advance signalling triangle. It is important to note that this driver was not aware that the Highway Code recommends the use of hazard warning flashers under circumstances of rapid deceleration.

For the sixteen motorists who declare that they use their hazard warning flashers, (and declare having used them over the past year), most of the road events that led them to use them were situations of a sudden slowing down of traffic or the presence of traffic jams on the motorway and along expressways and more rarely, a personal problem related to their vehicle (breakdown or stop on the hard shoulder) or arrival on the scene of an accident.

It is important to note at once that for the majority of the motorists interviewed, the use of hazard warning lights is far from systematic and depends largely on the nature and characteristics of the road incidents that they face. We will also see that for certain motorists there is an alternative to the use of hazard warning lights as a means of issuing a warning: repeated pressing on the brake pedal. Finally, one would indicate that certain motorists refrain from using their hazard warning lights due to the fact that the button is not easy to access in their vehicle.

Generally speaking, hazard warning lights are reserved for use in the case of road incidents that are considered to be sufficiently serious from a safety point of view to require specific communication and warning actions in favour of other users.

The main variables that the use of hazard warning lights seem to depend on are related to the nature of the critical event ahead (general slowing down or individual driver in difficulty), to its proximity (in terms of closeness and time), its magnitude, its duration, the extent to which it is predictable and finally, the presence and closeness of the other users behind, for whom the warning message is intended. Thus, the use of hazard warning lights depends as much on the road situation ahead as on the road situation further back.

It is important to stress that the variables we have identified concern both the triggering of a warning message by the driver and the passing on of a warning message sent by one or several motorists located ahead.



#### 3.2.1.2.1 Closeness of the critical event: giving priority to mastering the situation

It is interesting to note firstly that the use of the hazard warning lights depends on the closeness of the critical event ahead. When the critical event occurs in a zone that is « nearby », the main priority for motorists is obviously to cope with the situation they face before undertaking any specific action to communicate with road users approaching behind them.

*"But it's true that sometimes, when you have to slow down all of a sudden, you only think of one thing: controlling the vehicle...so that you don't go into the back of the person in front. And its only afterwards that you remember that there are people behind who are approaching fast and that's when you think of pressing the warning button"*

*"When it's (the slowing down) sudden, you don't have time to use the warning lights"*

*"Well in any case, I brake first and after that I press the warning button! ... I don't do the reverse! I brake first and then I think "look out!"*

"Hey its obvious, if I have to brake suddenly, I'm not going to press the warning button am I...if I have to stop really suddenly, to avoid an incident, I'm not going to press it".

#### 3.2.1.2.2 Nature of the critical event

There are two main groups of events that lead motorists to use their hazard warning lights.

a) The first group concerns incidents involving only one vehicle : broken down vehicle or stationary vehicle on the hard shoulder. The potential impact of this type of incident is generally limited to those users who are in close proximity. The motorists confirm that it is important that all drivers having this kind of problem inform others. However, it is not always necessary for a driver who witnesses this type of incident to send out or pass on a warning message by triggering his or her hazard warning lights. It all depends on the location of the driver in difficulty on the traffic lanes and on the possibility of the vehicle being a sustainable obstacle that prevents other motorists behind from progressing. If the driver in difficulty is already on the hard shoulder, the problem is considered as being solved and as a result does not need to

be pointed out (unless possibly if the vehicle is rather large in size and encroaches on one of the traffic lanes).

"If it's a vehicle that has broken down on the hard shoulder, I don't because, well, the car is on the hard shoulder...you see"

"If the driver puts his hazard warning lights on and stays on the traffic lane, then it means that there is maybe an obstacle on the road and I pass on the message, but if he puts his hazard warning lights on and moves towards the right, then it means he has a problem with his vehicle and in that case I don't put them on".

"Yes but it depends where the car is, in fact you can see ahead if we're all concerned, for example, as in the case of a traffic jam, in which case I use them, but if its a car that has stopped on the side of the road, like a breakdown or something, I don't put them on".

b) the second group concerns events that are likely to have a sustainable impact on all the users: a general slowing down of the flow of traffic during heavy traffic, a traffic jam or an accident. It is mainly under these conditions and depending on the characteristics of the event as described in detail below, that motorists send out or pass on a warning message using their hazard warning lights.

#### 3.2.1.2.3 Magnitude, duration and predictability of the critical event

In their description of situations where they declare that they used their hazard warning lights (and the situations in which they consider it useful to use them), the motorists stress the sudden, unforeseeable nature of the critical event that they are confronted with, along with its duration and the extent to which they have to reduce their speed in order to adapt to the circumstances.

*"When you put your hazard warning lights on its because the slowing down really lasts a long time and your speed is going to drop considerably..."*

*"When I'm going to have to brake a bit more suddenly and slow down a lot faster than I should have done...within a timescale that I consider reasonable...I'm not going to use it every time I slow down, but in situations, ...I use it every time its dangerous".*

*"Behind a traffic jam, one that the cars behind can't see. So I use my hazard warning lights to warn that the traffic has slowed down".*

*"Its when the traffic suddenly slows down in a way that isn't...that it isn't possible to anticipate, or in a way that I haven't anticipated, and so I presume that those behind me won't anticipate it".*

*"Well yes,...to indicate that I have to do something, um, that he hasn't been able to anticipate, so its not what I should have done...I use it in cases where the person behind is going to be surprised by my behaviour".*

Conversely, in situations that are considered easy enough to foresee or as standard, the use of hazard warning lights is not deemed necessary. This is the case for example on certain stretches of road and/or at certain times of day where slow traffic is frequent and regular.

*"Well in one specific place, the traffic always slows down...so, um, of course... I don't use it, because I tell myself that people are like me, that they know,...that there's always a slowing down of traffic in that place because its people who travel along that road to work on a regular basis, so I don't use them in fact..."*

### *3.2.1.3 Presence and proximity of approaching road users*

Finally, and this seems logical in terms of communication, the use of hazard warning lights depends on the presence and the closeness of other approaching motorists and their presumed capacity to perceive and react to the onset of the critical event.

Thus, most motorists declare that they do not trigger their hazard warning lights if there are no motorists behind them or when those that are behind them are quite a long way away.

*« (uses the hazard warning lights) If there are cars behind. If there is someone behind me, I press on the hazard warning lights! Well, yes it depends on whether there are people behind me ».*

*« Hum, sometimes, when the traffic slows down suddenly, if the car behind is far enough away, I brake and that's it... ».*

*« But, it depends how far back the people... I don't....not all the time...it depends on the distance".*

In the same way, they don't use their warning lights if they consider that the users behind them are in a position to perceive and react in time to the critical event.

*"If the person coming up behind me, has good visibility or doesn't... and I decide..."*

*"If there's no risk, if I see that he (the driver behind him) will have time to brake, I don't put my hazard warning lights on ..."*

#### *3.2.1.4 Understanding the origin of the critical event and/or the sending of a warning message by another person.*

As we have already stressed, the use of hazard warning lights on motorways and expressways is very much associated with the notion of danger and takes on a warning function.

The characteristics of the situational context and in particular, the general traffic conditions, seem to play a major role in the way a warning message sent out by another driver is interpreted. Thus, under conditions of heavy traffic, the use of hazard warning lights by another person refers to a general difficulty, i.e. one that concerns all the motorists. We have noted that it is mainly under these circumstances that motorists pass on the warning message by putting on their hazard warning lights also. Conversely, when there is little traffic, if an isolated vehicle puts its hazard warning lights on, it is interpreted as referring to a specific difficulty, one that concerns only the driver of the vehicle that sent out the message. It is therefore a question of a limited problem and motorists do not necessarily pass on the message. Although the motorists consider that the use of hazard warning lights by drivers further ahead is in itself sufficient to justify action or preparation for action on their part, they do however stress that it is not always easy to understand the origin or the cause of this warning.

*"Most of the time, you don't understand straightway. First of all you react by braking or by slowing down and after that you understand what's happening... so no, I think it's not easy, or at least you understand the basic message telling you there's a danger, that something needs to be done, now the true reason isn't obvious with these hazard warning lights".*

"No, we can't get a clear idea of what is ahead, we don't know what is ahead. On the motorway there are the hazard warning lights and we slow down, we're careful: we

don't know whether there's something ahead, if he's just doing that for fun; its really...he's put his warning lights on so we think that the traffic is moving slowly, that something is happening, so we slow down, that's it".

"Its that there's a problem, that the traffic is not the same as usual in brackets, but as to the reason why, after, its a question that you might get an answer to a bit further ahead once you see the damaged car or the car that has broken down or simply a traffic jam, ...but at the time, you just can't know".

*"Slow down and try to understand what's happening"* is often the answer motorists give to questions concerning their reactions in relation to the use of hazard warning lights by users further ahead. This « need for understanding », even if it is not the main priority, particularly in emergency situations, to a certain extent stresses the importance of specifying the nature of the event in the new IVHW system. This « need for understanding » would be even greater, if, as certain motorists suggest, it conditioned the fact that a warning message sent out by another driver was to be immediately passed on or not (without having checked its « pertinence » by themselves).

### *3.2.1.5 An alternative to the use of hazard warning lights: repeatedly pressing on the brake pedal*

We have examined above the variables taken into account by motorists before they use their hazard warning lights as a means of warning other users. It is important to add that half of the motorists evoke repeated pressing on the brake pedal as an alternative to the use of hazard warning lights. In their eyes, brakes are also used to warn and communicate with motorists behind. Repeated use of the brake pedal in certain cases has the advantage of associating the action (or the preparation of the action) more directly with communication.

Although, from the interviews, it is not easy to clearly distinguish those situations that lead motorists to use one mode of communication rather than another, it seems that there is a certain progressiveness in the warning value allocated to each of the different approaches: repeatedly pressing on the brake pedal is often described as

an alternative to the hazard warning lights when the critical event is not very urgent, in particular when the traffic behind is a long way away.

"Sometimes, well, sometimes, it is, you just need to warn with a quick jab on the brakes to say careful, the traffic is slowing down, but that's all, its not that everyone is at a standstill..."

"Well, its when for example, I look in my rear mirror and there's no car right behind me...when the car is a bit further back...or when the slowing down isn't sudden in fact, ...isn't hurried..."

"If the traffic slows down, (doesn't necessarily use them) because I also use my brakes as a warning, in other words I just press on the brake pedal to activate the tail lights so that they understand... I also use it as a warning message, the brake lights... so it really has to be,... really sudden in order for me to use the hazard warning lights. Otherwise, when I've got time to use the brake pedal I use the brake pedal".

#### *3.2.1.6 A limit to the use of hazard warning lights in an emergency situation: the location of the control button*

During the interviews, we asked the motorists to specify where the hazard warning light control button was located in their car.

Generally speaking, the motorists all stressed the diversity of their location, depending on the brands and for the twenty motorists interviewed, we listed six different locations: to the left or the right of the steering wheel, at the centre of the dashboard, on the steering wheel, near the gear box or on the roof lamp. These locations are considered as more or less accessible by the motorists, in particular in an emergency situation and for six of them, their inaccessibility is the reason why they rarely use their hazard warning lights.

*"Well, I have to lean forwards in fact, if you like I have to move in order to reach it...well, yes it requires an effort...especially if I'm in the process of braking hard".*

### **3.2.2 Motorists' reactions to the concept of a new warning system and a priori representations of the conditions of use.**

We remind the reader that the second part of the interview began with the reading of the explanatory notice for the IVHW system. The motorists were then asked to explain the conditions under which they would use this new system.

Firstly we will present the motorists' general reactions to the system's design and then we will briefly examine the main questions raised about the way it works. Finally, we will specify and discuss the motorists' representations as to the conditions of use.

#### *3.2.2.1 General assessment of the early warning concept proposed by the IVHW system.*

All the motorists questioned consider that early warning of a critical road event would promote safe driving, especially when speeds are high on roads and motorways. Thus, the principle of the IVHW system is generally well accepted by motorists.

Among the standard situations presented in the explanatory notice, automatic triggering of the system in the case of an accident is an aspect that is particularly appreciated (both for the driver who has suffered an accident and who is therefore easier to see, particularly at night time or on roads where there is little traffic, and for the other users who could be involved in a second accident caused by the first). In the same way, early warning under circumstances of rapid deceleration, particularly in poor weather conditions (night, rain, fog or a bend) are a very useful extension to the current hazard warning lights. However, the motorists consider that triggering the system in the case where a vehicle stops on the hard shoulder, coordinating it with the current use of hazard warning lights is less useful.

#### *3.2.2.2 Questions and remarks from motorists on the way the IVHW system works*

Although the system design received approval, the motorists have numerous questions concerning the way it works. It is important to note that the presentation document for the system did not provide much information on this point, which no doubt explains why the motorists had problems understanding, in particular

concerning the way that the warning messages are transmitted and retransmitted upstream (at a distance from a critical event).

After reading the instructions, the motorists also express a certain number of preferences as regards the contents and format of the warning messages to be sent by the system.

The main questions and remarks made on the instructions for use concerned:

- the way the warning message will be sent. The questions raised by the motorists concerned the true range within which messages can be retransmitted: how far back can the message be sent, can the distances be combined, how does one stop the transmission, etc. Questions also concern the way of locating the danger and the accuracy of the latter.

*"If its 900 m away and I turn it on, that means another 1000 m back, ... if the person who receives it, another 1000 m, its never ending...in fact, I don't know whether this system, if I re-transmit the message, whether this system is always going to take 900 m or is it going to calculate the distance?"*

"And then there's another problem, if, um, there's still the problem in one place, the cars that are 1000 m behind will be warned, if the last car to be warned also triggers its system, that will set it back a further 1000 m and one can imagine an absurd situation where you're warned of an incident 10 km away and the problem will no doubt be solved by the time you reach the spot".

- the modes for sending the warning messages: most motorists express a preference for a two-mode approach that is both with sound and visual. Priority is however given to sound, mainly for reasons of visual load.

- the contents of the warning message: the majority of the motorists consider that it is important to have a precise indication as to the nature of the danger and its location. A minority consider, however, that a simple danger signal would be sufficient. Information on the location and proximity of the danger are also considered as important, maybe not necessarily expressed as the distance from the obstacle but more as the time it will take to reach the obstacle, which depends on the speed of the



vehicle. The experimental results of the BAST should cast a useful light on these points.

- as for the hazard warning lights, the motorists stress that the location of the control button for the IVHW system is important and that its position will condition their usage, in particular in an emergency situation.

### 3.2.2.3 *A priori representations of the conditions under which the motorists would trigger the IVHW system*

#### 3.2.2.3.1 Triggers of the IVHW system and sending a warning message

For all the motorists, it is clear that use of the system in urban areas is totally excluded. It is only for use on motorways and expressways when vehicles are travelling at high speeds. This is very much in line with the principle based on which the system was designed.

Concerning the conditions under which they would trigger the system, opinions diverge.

For certain motorists, the system is an extension of the current hazard warning lights (*"its an improvement to ordinary warning lights"*) and they would use them under the same conditions (and according to the same variables) as those described previously (IV.1.2). The only major difference is that these motorists declare that they are more inclined to use it even if there are no users further back, since the range of the system is by definition greater.

However, for other motorists, the system would not be used in the same way as the current hazard warning lights, insofar as sending a warning message using the IVHW system is considered as more "involving" since it concerns a greater number of users. For this reason, the system would only be triggered in situations that are « more dangerous » than those in which they usually use their hazard warning lights.

*"The warning lights are for when there's the possibility of a problem, you can put them on and here, I think its even more important, you turn them on when there is really something more important, I have the impression that..."*

"I'd possibly use it in a situation where the warning lights were not enough in fact".

Thus, the IVHW system would be perceived more as an additional warning mode than as a replacement for the current hazard warning lights, or even as an addition to the alternative warning mode already mentioned, repeatedly pressing on the brake pedal. Its main advantage is that it covers situations where poor visibility limits the utility of the two other modes.

#### 3.2.2.3.2 Relaying a message received using the IVHW system

Although as we have already indicated above, most of the motorists were in favour of the system and could see the advantage of receiving early warning in critical driving situations, the majority of them have questions as to the risk of « useless » or « excessive » use by users who are « too careful » or « too fearful ».

*"But I think that can contribute, if there's a false alert... I can imagine elderly people, maybe they'll be a lot more worried... messages that they'll have already received from cars ahead, and they'll use the system at an untimely moment...and in that case, I think it could cause traffic to slow down...uselessly...uselessly".*

These reservations are clearly illustrated in the discussion on relaying or not relaying a warning message sent out by another user. Half of the motorists declare that if there is a long distance between them and the danger, they would not send on the warning message immediately and would wait until they had validated it to a certain extent « with their own eyes ».

"If I see a warning message ...well, I think I'd tend to wait until I reached the site of the incident...to see what was really happening, you know...if I see "slow traffic" and there's nothing at all, I won't turn it on, ...no, I think, in my opinion, it may have the same effect as the warning lights and you think "its not worth using it", well, I don't know..."

"Well, I have no idea ...because it's...a question of trusting the person who's facing the danger, that might not even occur...No, I don't think so... I think I'd wait and see for myself before I pressed the button..."

"In fact, I think I'd trigger it as soon as I realised ...what the danger was in fact".

### 3.3 Summary and discussion about the results

The exploratory study carried out by INRETS aims firstly at analysing motorists' current representations and practices in the use of hazard warning lights as a warning and communication mode with other users and secondly, to examine how and to what extent the new warning system would integrate with these practices. Our study is complementary to the study developed by the BAST and it will be important to put our respective results into perspective.

The approach that we adopted is an intensive approach based on in-depth interviews carried out with twenty motorists. The results obtained, in our opinion, provide a useful basis for future, more systematic studies that will make it possible on the one hand to quantify the trends identified in our study, and on the other, to carry out experiments to validate and parameterise the variables that determine the use of hazard warning lights and the IVHW system.

The main results obtained are the following:

a) For the majority of the motorists questioned, the use of hazard warning lights as a mode of communication and warning is a well-established practice. We note that the younger motorists declare that they acquired this approach through their training (and in reference to the Highway Code), whereas for a number of motorists, this approach has established itself over time on the basis of « social learning ».

*"Well, if I've learnt to use my hazard warning lights, its from watching others...I didn't learn it during my driving lessons...I learnt it by watching ...".*

*"I've seen that gradually others have done it and I've seen that hazard warning lights are used more and more and now I do the same when the traffic slows down".*

Only four of the motorists declare that they have not adopted this warning mode when driving.

b) Depending on the context, on whether it is an urban or rural zone, the functions allocated to hazard warning lights are of a very different nature and clearly demonstrate the advantage of distinguishing between the hazard warning light controls and those of the IVHW system.

c) For the majority of the motorists interviewed, whether or not they use their hazard warning lights as a means of warning depends greatly on the nature of the road

events that they are about to face ahead of them (accident, general slowing down or difficulty experienced by an individual driver and the variables that characterise them: proximity (spatial and/or in terms of time), magnitude, duration and the more or less predictable nature of the incident. Finally, it depends on the presence and proximity of the other users ahead. For half of the motorists questioned, there is an alternative warning and communication mode, in other words, repeated pressing on the brake pedal and it would seem that there is a certain amount of progressiveness in the warning value allocated to each mode. Moreover, we have seen that, for certain motorists, the IVHW would in a way be a third warning mode, reserved for particularly critical road incidents. Our results have enabled us to identify a certain number of variables that it will be important to take into account in future experiments in order to study in a systematic manner the methods of use of the new IVHW system. In particular, the results suggest that such experiments should present motorists with scenarios that include the different variables that characterise the road situations ahead (downstream) and behind (upstream) and that enable them to use different warning and communication modes with other users: putting on the brakes, hazard warning lights and the IVHW system. These experiments would also make it possible to validate the a priori representations of the conditions of use of the system, and in particular, the distinction that seems to be made between the warning message sent by the driver and the retransmission of a message to a third party.

d) The majority of the motorists questioned approved of the early warning concept in the case of a critical road event as proposed by the IVHW system. It is important, however to stress that the operating mode, at least as it was presented briefly in the presentation document, is not always fully understood by a number of motorists. It would be interesting in a future study to complete a more in-depth analysis of these representations insofar as they could play an important role in the use of the system.

## 4 REFERENCES

- /1/ Evers, C. & Gelau, C. (2002). Safety Relevant Issues of Inter-Vehicle Hazard Warning Systems: A Human Factors Perspective. Paper presented at the ERTICO e-Safety Conference, Lyon, France, September 16-18, 2002.
- /2/ Laan, J.D. van der, Heino, A. & De Waard, D. (1997). A simple procedure for the assessment of acceptance of advanced transport telematics. Transportation Research C, Vol. 5(1). 1-10.

## 5 ANNEXES

<b>Annex I</b>	<b>Answers to the questions in the questionnaire (German)</b> .....	<b>36</b>
<b>Annex II</b>	<b>Questionnaire/Script used by the test leader (German)</b> .....	<b>46</b>

## **Verbesserungsvorschläge:**

Ton muss mit anderen Fahrzeugsystemen (Radio, lautes Gebläse, usw) koordiniert werden.

Der Piepston muss mit dem Radio koordiniert werden.

Bei nur 100 m Entfernung und großer Gefahr mehrmals Piepsen. Je mehr gepiepst wird, desto mehr Aufmerksamkeit ist gefordert.

Die Art der Gefahr ist wichtiger als die Entfernung.

Bei der ersten Warnung war die Entfernung von 700m o.k. 400m Vorwarnung sind zu kurz. Mindestens 500m.

Display sollte bei Sonne besser ablesbar sein

Andere Position des Displays, am besten im Kombiinstrument.

Die Warnungen sollte ich an Streckenmerkmalen (Kurve, Kuppe) orientieren.

Die Entfernungsangabe sollte durch unterschiedliche akustische Signale ausgedrückt werden. Das Display überfordert mich.

Ich wünsche mir einen Dauerton für hohe Gefahr.

Bei Stau wünsche ich mir als zusätzliche Information die Staulänge, wenn ich den Stau erreicht habe.

50m-Schritte bei Entfernungsangabe, damit man schneller erkennt, dass heruntergezählt wird.

Text zur näheren Erläuterung der Symbole. Ich hätte genug Zeit, um den Text und die Symbole zu lesen.

Auf „Achtung!“ verzichten und stattdessen „Unfall“, „Stau“ usw. in Textform anzeigen.

Die Meldung ist immer eine Warnung. Das „Achtung!“ ist deshalb überflüssig.

Meldung bedeutet: nun vorsichtig weiterfahren.

Spurinformation, wo eine Behinderung besteht und auf welcher Spur eine freie Fahrt möglich ist.

Die Anzeige sollte im Kombi erfolgen, da man eh auf den Tacho schaut.

Entfernungsangabe als Sprachausgabe („Stau in 600 m“).

Ein Entfernungsbalken ist besser als eine numerische Anzeige, weil ich aus der Veränderung des Balkens erkennen, wie schnell ich mich der Gefahrenstelle nähere.

---

Appendix I

Anzeige sollte im Kombiinstrument erscheinen, weil ich sowieso dort hinschaue, um den Tacho abzulesen.

Die Symbole sollten mehr Ähnlichkeit mit realen Verkehrszeichen haben. Eine Stauwarnung hat nun Mal einen roten Rand. Aber keine zu übertriebene Darstellung. Ich wünsche mir ein akustisches Signal für die Entfernungsangabe, z.B. „Stau in 400m“.

Vielleicht sollte der Warnton deutlicher sein. Dies kann dann aber auch störend wirken.

Zusätzliche Sprachausgabe.

Symbole durch Text erklären.

Unterscheidung der verschiedenen Dringlichkeit durch Farben und Blinken.

Die Anzeige sollte im Kombiinstrument erfolgen.

Unterscheidung der verschiedenen Dringlichkeit durch Farben und Blinken.

Die Anzeige sollte im Kombiinstrument erfolgen.

Die Dringlichkeit der Warnungen muss besser erkennbar sein.

Warnungen besser im Kombidisplay anzeigen.

Das System sollte die nachfolgenden (nicht ausgerüsteten) Fahrzeuge automatisch warnen, z.B. durch Einschalten der Warnblinkanlage oder pulsierende Bremslichter.

### **Berichtete Schwierigkeiten:**

Hauptproblem: Display spiegelt!

Bei der letzten (vierten) Warnung habe ich das Symbol nicht verstanden.

Text muss gelesen werden. Das lenkt ab.

Meiner Meinung nach wurden zu oft Meldungen ausgegeben.

Ungewohnt war die Anzeige in der Mitte. Nach 2 Meldungen habe ich mich daran gewöhnt.

Akustisches Signal lenkt vom Verkehrsgeschehen zunächst ab.

Auch wenn ich einen Tempomat benutze, strengt mich die Bedienung zunächst an. Dann habe ich jedoch den Gewinn, dass ich nicht mehr auf die Geschwindigkeit achten muss.

Symbole sind ohne vorherige Erklärung schwer zu erkennen.

Die wesentliche Botschaft ist: Achtung, jetzt kommt etwas!



---

Appendix I

Das System ist auf keinen Fall überflüssig.

Die Vorwarnung ist gut

Die Entfernungsinformation ist schwer umsetzbar. Probleme bereiten mir auch die unterschiedlichen Entfernungen, in denen gewarnt wird.

Das Unfallsymbol ist schwieriger zu verstehen.

Bei dem Unfall kam die Warnung zu spät.

Auf welcher Spur befand sich die Gefahr

Entfernungen sind schlecht abschätzbar.

100 m Vorwarnung sind zu wenig.

Es ist für mich ungewohnt, auf Dinge zu reagieren, die ich nicht selbst sehe.

Ich habe mich schwer getan, die Entfernungsangaben umzusetzen und habe sie nicht bewusst registriert.

Bei hohen Geschwindigkeiten habe ich Probleme, Entfernungen abzuschätzen.

Ich würde mich auf die Systemausgaben verlassen, vor allem auf die Entfernungsangaben, insbesondere dann, wenn runtergezählt wird. Aber wann fängt ein Stau genau an ? Gibt es einen Übergangsbereich ?

Schwer zu sagen, weil ich mir nicht sicher bin, was die Symbole bedeuten. Ich würde mir normalerweise zunächst die Bedienungsanleitung durchlesen. Ich habe immer lange überlegt, was die Symbole bedeuten könnten. Was heißt eigentlich Stau ?

Ich habe die Entfernungen überschätzt und gedacht, die Gefahrenstelle sei weiter weg.

Nehme Entfernung erst beim zweiten Blick war.

Ich habe den Signalton nicht wahrgenommen.

Innerlich hatte ich das Gefühl, dass ich bei einer Warnung in weniger als 500 m Entfernung von der Gefahrenstelle in Stress komme.

### **Allgemeine Bewertung:**

Besonders bei der ersten Warnung: Piepston hat fast erschreckende Wirkung, Blick wird auf das Display gelenkt.

---

Appendix I

Habe beim vierten Mal mit Warnung vor einer Kurve oder Kuppe gerechnet und mich an den Piepston gewöhnt.

Warnungen gut sichtbar, Ton erweckt Aufmerksamkeit.

Das System ist gewöhnungsbedürftig, man muss Vertrauen entwickeln.

Am Anfang: Schwierigkeiten mit den Entfernungsangaben, Vertrauen in das System fehlt noch.

Man entwickelt eine Sensibilität für Gefahrensituationen.

Nur bei großen Entfernungen ist genug Zeit, den Gefahrentyp zu erkennen.

Man schaut eher auf die Entfernung.

Ich habe generell Schwierigkeiten, Entfernungen abzuschätzen. Was bedeuten 800 m ?

Ich finde das System gut.

Man erschrickt nicht, wird aufmerksam und hat genug Zeit.

Ansonsten war die Anzeige gut.

Warnungen gut ablesbar.

Gut, dass Symbole und kein Text verwendet werden.

Ich bin ganz gut mit dem System zurechtgekommen.

Es waren unaufdringliche Hinweise auf Gefahrensituationen.

Die Ablesbarkeit war gut durch die große Darstellung.

Der Nutzen des Warnsystems ist die Vorwarnung.

Der Piepston würde zunächst ausreichen, der Gefahrentyp ist für mich nicht relevant.

Die Anzeige ist schön groß und übersichtlich.

Die Position der Anzeige ist entscheidend.

System ist hilfreich durch frühe Information (400 m und 300 m vorher).

Es ist gut, dass die Entfernungen heruntergezählt werden, weil das Einschätzen von Entfernungen schwierig ist.

Die Symbole für Stau und Fahrzeug auf dem Standstreifen sind gut verständlich.

Die Symbolgestaltung ist eindeutig.

Gut, dass die Anzeige bewusst einfach gehalten wurde.

Die Symbole waren besser zu erkennen, da sie statisch sind.

Habe auf die Warnung hektisch reagiert.

Als unterstützende Maßnahme ist das System sehr gut.

---

Appendix I

Sehr gut.

Der Pieps ist gut.

Gut ablesbar.

Größe und Einfachheit der Anzeige sind in Ordnung.

Die Verwendung von Piktogrammen fördert die Erkennbarkeit.

Die Art der Gefahr ist wichtiger

Die Anzeige lenkt zwangsläufig vom Verkehr ab.

Die Art der Gefahr und die Entfernung sind gleich wichtige Informationen, um abrupte Reaktionen zu vermeiden.

Durch das System ist man vorbereitet.

Der Piepston ist angenehm: Jetzt muss ich schauen.

Schaue nur auf die Bilder.

Würde sofort bremsen! Empfinde die Warnung als unmittelbare Gefahr!

In einer Realsituation würde ich nur noch nach vorne auf den Verkehr schauen, nicht mehr auf das Display.

Die Bilder sind verständlich.

Ein Signalton hätte vielleicht eine erschreckende Wirkung.

Gute Sache.

Die dritte Meldung hat vor einem Stau in einer unübersichtlichen Kurve gewarnt. Der Pieps und die Meldung führen zu einem konzentrierteren Fahren.

Gefahrentyp und Entfernung sind mir gleich wichtig.

Ton ist gut.

Symbole sind in Ordnung.

Eventuell verschiedene Farben für die verschiedenen Gefahrentypen (zur Zeit alle weiß).

Sprachausgabe, z.B. „Achtung Stau“.

Radio sollte Ausgehen, wenn Warnton ausgegeben wird.

Telefoniert der Fahrer, wenn eine Warnung ausgegeben wird, sollte ihm signalisiert werden, dass er seine Aufmerksamkeit auf den Verkehr richten sollte.

Es sollten Verkehrs- und/oder Gefahrenzeichen angezeigt werden.

Bei wirklichen Gefahren wie einem Stauende sollte eine Sprachausgabe erfolgen.

---

Appendix I

Anzeige des Gefahrentyps und der Entfernung ist zu viel. Ich habe die Zahlen schneller wahrgenommen: Gefahr in soviel Meter. Das Symbol habe ich nicht realisiert.

Mit dem System lernt man das Entfernungsschätzen. 50m sind viel für den Bremsweg.

Die Ereignisse werden gut und deutlich angezeigt.

Die Art der Gefahr ist egal. Es geht nur darum, dass man vorsichtig weiterfährt. Die Art der Gefahr beeinflusst mein Verhalten nicht. Trotzdem sind die Bilder ein guter Hinweis.

Die Art der Gefahr ist egal. Es geht nur darum, dass man vorsichtig weiterfährt. Die Art der Gefahr beeinflusst mein Verhalten nicht. Trotzdem sind die Bilder ein guter Hinweis.

System sehr gut zu verstehen

Genügend Zeit, um Verkehrsfluss zu beobachten und die Entfernungsangabe zu verfolgen. Ich habe mich auf die Entfernungsangabe verlassen.

System bringt deutlich mehr Sicherheit und führt zu einem konzentrierteren Fahren.

Innerlich hatte ich das Gefühl, dass ich bei einer Warnung in weniger als 500 m Entfernung von der Gefahrenstelle in Stress komme.

Insgesamt empfand ich das System als angenehm.

Die Warnungen waren gut zu erkennen und unkompliziert.

Die Fahrt war für mich aufgrund der Testsituation nicht realistisch. Ich war mehr angespannt als sonst.

Nach der Hälfte ist mir aufgefallen, dass die Entfernung runtergezählt wird.

Die Entfernungsangaben sind nicht umsetzbar.

Simulierte Warnungen können nicht zur aktuellen Situation passen.

Die Ablenkungswirkung war zu hoch. Es ist eine Gewöhnungsphase notwendig.

Beim ersten Signal habe ich mich sehr erschrocken.

Symbole waren gut.

Entfernungsangabe lenkt teilweise ab.

Nachteil: Andere haben das System nicht. Reaktion muss an das Verhalten der anderen Verkehrsteilnehmer angepasst sein. Ich habe eine Verantwortung gegenüber den anderen. Deshalb die teilweise zögerliche Reaktion.

---

Appendix I

Es fehlte das reale Auftauchen der Gefahr, um zu reagieren.

Würde die Warnungen nicht ignorieren.

Das reale Erleben der Gefahrensituation fehlt.

Ich hatte immer genug Zeit, auf die Warnungen zu reagieren, da die Entfernung immer größer war als 300m.

Normalerweise nehme ich zuerst den Fuß vom Gas, dann bremse ich.

Der Piepston wirkt unbewusst. Er erschreckt nicht und lenkt den Blick auf das Display.

Bei der Rückfahrt habe ich mehr auf die Entfernungsangaben geachtet, weil ich wusste, dass die Warnungen nicht so dringend sind.

Die Ablenkung durch das System nimmt mit der Zeit ab.

Ich war positiv überrascht von der großen Vorwarnzeit.

Der Fahrer wird durch die Warnung aufmerksam.

Klasse Sache, wenn es in echt funktioniert.

Einfache und gute Handhabung, auch ohne Erklärung.

### **Akzeptanz (Kaufverhalten):**

Ich habe noch kein Vertrauen in das System. Das kommt vielleicht, wenn die Warnungen in realen Situationen erfolgen.

Ich habe mich schnell an das System gewöhnt. Bei der Rückfahrt habe ich mich sicherer gefühlt.

Ich würde mich sehr auf das System verlassen. Wenn es mal im Auto ist, dann funktioniert es auch. Fehlalarme würde ich akzeptieren.

Ich hätte kein blindes Vertrauen in das System.

Bei anderen könnte ich mir vorstellen, dass sie dem System blind vertrauen.

---

Appendix I

Ich kann nicht sagen, ob ich mich auf das System verlassen würde, weil ich die Funktionsweise nicht kenne. Das System hat mit meiner eigenen Sicherheit zu tun. Es fehlen mir die realen Rückmeldungen.

### **Sonstiges:**

Meine Reaktion orientiert sich an der Verkehrssituation.

Ich nehme das Gas weg und bremse.

Ich denke, man gewöhnt sich an das System.

Ich habe auf den Piepston reagiert, auf das Display geschaut und die Entfernungsangabe wahrgenommen

Kann nicht sagen, ob ich zuerst auf den Gefahrentyp oder die Entfernungsangabe geschaut habe.

Bei den letzten 2 Warnungen habe ich verstanden, was ich machen soll.

Ich habe mich auf die Entfernungsangabe verlassen.

Ich habe sowohl die Symbole als auch die Entfernungsangaben wahrgenommen.

Es wurde sowohl die Gefahrenart als auch die Entfernung zur Gefahrenstelle angezeigt.

Habe mich stark an Entfernungsanzeige orientiert.

Ich wurde akustisch und optisch informiert, über die Art der Gefahr und die Entfernung.

Es wurde sowohl die Art der Gefahr als auch die Entfernung angezeigt.

Die Entfernung wurde runtergezählt (bis auf die zweite Warnung).

Ich habe zuerst den Gefahrentyp, dann nur noch die Entfernung wahrgenommen.

Ich weiß nicht, ob ich auf eine echte Gefahr genau so reagieren würde. Auf alle Fälle würde ich langsamer werden und bremsen.

Ich würde nicht blind reagieren, sondern suchen, was los ist.

Habe peripher wahrgenommen, dass sich auf der Anzeige etwas verändert hat.

Ich bin mir nicht sicher, ob ich eine Meldung verpasst habe. Vier Meldungen habe ich bemerkt.

Ich wurde über die Art der Gefahr und die Entfernung informiert. Die Warnung bedeutet Achtung, Vorsicht! Bitte aufpassen!

---

Appendix I

Ein Unfall ist aber etwas anderes wie ein Stauende. Bei einem Unfall würde ich mit einem unkontrollierten Verhalten und plötzlichen Spurwechseln der anderen Verkehrsteilnehmer rechnen. Ein Stau wirkt sich eher auf alle Fahrspuren gleichermaßen aus.

Bei der ersten Meldung habe ich nur die 700m gesehen und versucht, die Entfernung abzuschätzen. Bei der zweiten Meldung habe ich bemerkt, dass die Entfernung runtergezählt wird, und habe mich auf diese Angabe verlassen.

Ich habe mich hauptsächlich an den Entfernungsangaben orientiert.

Beim 3. Mal war die Anzeige schnell wieder weg – bei etwa 400 m. Ich glaube nicht, dass ich so schnell war und in der kurzen Zeit diese Entfernung zurückgelegt habe.

Ein-/Ausfahrten stellen keine besonderen Gefahrensituationen dar. In diesen Bereichen fahre ich ohnehin mit erhöhter Aufmerksamkeit.

Ich habe zwei Symbole wahrgenommen: Stau und Unfall.

Habe auf den Piepston reagiert. Was wird gemeldet ? Wie weit ist es noch ?

Bei der Rückfahrt: Habe sowohl die Entfernung als auch den Gefahrentyp wahrgenommen.

Der Gefahrentyp war für mich die primäre Information. Daran passe ich mein Verhalten an. Bei einem Unfall bremsen ich schnell ab. Bei einem Stau nehme ich zunächst das Gas weg und warte ab, ob es sich um stockenden Verkehr oder um einen Stau handelt.

Erhalte ich die Warnung in 600 m Entfernung von der Gefahrenstelle, habe ich genug Zeit, um zu reagieren.

Bei einer Warnung in 400 m Entfernung bleibt dagegen zu wenig Zeit.

Ich hätte nicht gedacht, dass ich die angegebenen Entfernungen so schnell zurücklegen würde.

Nach dem Gespräch beim Zwischenstopp habe ich mehr auf die Symbole und weniger auf die Entfernung geachtet.

Die Verkehrszeichen sind wichtiger.

Ich orientiere mich hauptsächlich an der realen Situation.

Auf der linken Spur bremsen ich nur im Notfall.

Man darf nicht so in Hektik verfallen wie ich am Anfang. Man muss ruhig und gelassen bleiben.

---

Appendix I

- Am Anfang habe ich nur auf mich selbst geachtet. Bei der Rückfahrt verstärkt auf andere Verkehrsteilnehmer.

Ich hatte genügend Zeit, mich auf die Gefahrensituationen einzustellen.

Die Bildchen kann jeder verstehen, da sie starke Ähnlichkeit mit Verkehrszeichen haben.

Bei der Rückfahrt konnte ich die Symbole und die Entfernung wahrnehmen.

Das Abschätzen von Entfernungen ist für mich kein Problem. 400m ist die Entfernung von meinem Elternhaus zur Hauptstrasse. 100m sind es bis zum Nachbarn. 200m bis zum Bauern.

Man müsste wissen, dass nur mittelfristige Warnungen kommen, dann würde man nicht sofort Bremsen.



## Fragebogen für die Versuchsdurchführung

Variante:

Vp.-Nr.:

DEUFRAKO: IVHW

DC/BASt

### Felduntersuchungen zum IVHW-Anzeigekonzept

#### Leitfaden für den Versuchsleiter

##### 1. Instruktion vor Fahrtbeginn (frei):

Ziel dieser Untersuchung ist es, Erfahrungen mit der Verständlichkeit und Nutzbarkeit eines neuartigen Warnsystems zu sammeln, das wir hier in diesem Versuchsfahrzeug installiert haben. Dieses System soll den Fahrer bei Autobahnfahrten und auf Landstraßen frühzeitig über Ereignisse wie z.B. das bekannte „Stauende hinter einer Kurve“ warnen und ihm so Gelegenheit geben, sein Fahrverhalten rechtzeitig darauf einzustellen.

*Um nun zu sehen, wie Sie mit diesen Warnmeldungen zurechtkommen werden wir nun eine ca. einstündige Autobahnfahrt machen. Dabei wird das System in unregelmäßigen Abständen Warnmeldungen ausgeben. Natürlich zeigen diese keine realen Gefahren an, da dieses Fahrzeug z.Zt. noch das einzige ist, das mit diesem System ausgerüstet ist und es sich natürlich auch verbietet, Gefahren im Straßenverkehr zu erzeugen, auch wenn dies Untersuchungszwecken dient.*

*Wir möchten Sie um folgendes bitten:*

## Appendix II

- *Bitte passen Sie Ihr Fahrverhalten dem Warnhinweis entsprechend an, d.h. als ob er echt wäre. Natürlich müssen Sie dabei auch darauf achten, dass wir im realen Verkehr sind, d.h. Sie sollten durch ihr Verhalten weder sich selbst noch andere Verkehrsteilnehmer gefährden. Die Fahrsicherheit hat immer Vorrang!*
- *Geben Sie bitte nach dem Erscheinen einer Warnung durch Berühren dieses Touch-Screens an, an welcher Stelle Sie mit der Gefahr rechnen würden, wenn es sich um eine „echte“ Warnung gehandelt hätte.*
- *Ein kurzes Antippen des Touchscreens genügt.*
- *Sie haben stets genügend Zeit, um auf die Warnung zu reagieren und den Touchscreen zu berühren. Es handelt sich weder um einen Leistungstest noch um eine Reaktionszeitmessung! Vielmehr geht es uns um Ihre persönliche Einschätzung der Situation.*
- *Im Anschluss an jede Warnung werden wir Ihnen noch einige kurze Fragen zu dieser Warnung stellen*

Bevor wir losfahren, noch einige Hinweise:

- Bitte stellen Sie den Sitz, das Lenkrad und die Spiegel ein (Kontrolle der Sitzposition mit der Kamera).
- Bitte tragen Sie keine Sonnenbrille.
- Bitte fahren Sie ohne Tempomat.
- Bitte schalten Sie das Radio, Navigationssystem usw. aus.

2. Während Fahrtabschnitt 1 zu jedem Ereignis (Abfrage nach jedem Ereignis über den Touch-Screen)

Ereignis 1:

- Was für ein Ereignis hätten Sie jetzt erwartet?

- Hätten Sie in einer Realsituation auch so reagiert, oder anders?

Ereignis 2:

- Was für ein Ereignis hätten Sie jetzt erwartet?
  
- Hätten Sie in einer Realsituation auch so reagiert, oder anders?

---

Appendix II

Ereignis 3:

- Was für ein Ereignis hätten Sie jetzt erwartet?

- Hätten Sie in einer Realsituation auch so reagiert, oder anders?

Ereignis 4 :

- Was für ein Ereignis hätten Sie jetzt erwartet?

- Hätten Sie in einer Realsituation auch so reagiert, oder anders?

5.1.1.1.1



### 3. Zwischenbefragung (Offenes Interview)

- Wenn Sie jetzt Zwischenbilanz ziehen, wie sind Sie mit dem System zurechtgekommen ?

- Welche Einstellungen würden Sie verändern wollen ?

- Nur, wenn während der Fahrt nichts gesagt wurde: Sicher ist Ihnen aufgefallen, dass es verschiedene Warnanzeigen gab. Was haben diese bedeutet ?

4. Während Fahrtabschnitt 2 zu jedem Ereignis (Abfrage nach jedem Ereignis über den Touch-Screen)

Ereignis 1

- Was für ein Ereignis hätten Sie jetzt erwartet?

- Hätten Sie in einer Realsituation auch so reagiert, oder anders?

Ereignis 2

- Was für ein Ereignis hätten Sie jetzt erwartet?

- Hätten Sie in einer Realsituation auch so reagiert, oder anders?



---

Appendix II

Ereignis 3:

- Was für ein Ereignis hätten Sie jetzt erwartet?
  
  
  
  
  
  
  
  
  
  
- Hätten Sie in einer Realsituation auch so reagiert, oder anders?

Ereignis 4:

- Was für ein Ereignis hätten Sie jetzt erwartet?
  
  
  
  
  
  
  
  
  
  
- Hätten Sie in einer Realsituation auch so reagiert, oder anders?

5. Abschlussbefragung

- Fragebogen zur Systembewertung Akzeptanzfragebogen (Anlage 1)
- Fragebogen zu Nutzbarkeit und Verständlichkeit (Anlage 2)

**Versuchsleiter:** Bitte bei starker Zustimmung zu den Items 2, 3, 4, 6, 8, 10 bzw. bei starker Ablehnung bei den Items 1, 5, 7, 9 nachfassen und Antworten stichpunktartig auf Rückseite notieren.

- "Willingness to pay" und Fragen zur Person (Anlage 3)

**Anlage 1**

Vp.-Nr./Datum:

**Fragebogen zur Systembewertung**

Mit den folgenden Adjektivpaaren möchten wir etwas über Ihre Meinung über das System erfahren. Für jedes Adjektivpaar stehen Ihnen fünf Antwortmöglichkeiten zur Verfügung, je nachdem welches der beiden eher zutrifft.

Nützlich	<input type="checkbox"/> <input type="checkbox"/> <input type="checkbox"/> <input type="checkbox"/> <input type="checkbox"/>	Nutzlos
Angenehm	<input type="checkbox"/> <input type="checkbox"/> <input type="checkbox"/> <input type="checkbox"/> <input type="checkbox"/>	Unangenehm
Schlecht	<input type="checkbox"/> <input type="checkbox"/> <input type="checkbox"/> <input type="checkbox"/> <input type="checkbox"/>	Gut
Erfreulich	<input type="checkbox"/> <input type="checkbox"/> <input type="checkbox"/> <input type="checkbox"/> <input type="checkbox"/>	Unerfreulich
Effektiv	<input type="checkbox"/> <input type="checkbox"/> <input type="checkbox"/> <input type="checkbox"/> <input type="checkbox"/>	Überflüssig

Appendix II

Unsympathisch	<table border="1"><tr><td></td><td></td><td></td><td></td><td></td></tr></table>						Sympathisch
Hilfreich	<table border="1"><tr><td></td><td></td><td></td><td></td><td></td></tr></table>						Wertlos
Unerwünscht	<table border="1"><tr><td></td><td></td><td></td><td></td><td></td></tr></table>						Wünschenswert
Aktivierend	<table border="1"><tr><td></td><td></td><td></td><td></td><td></td></tr></table>						Einschläfernd



Appendix II

6. Nach meiner Meinung waren in diesem System zu viele Widersprüche
7. Ich vermute, dass die meisten Leute sehr schnell lernen würden, dieses System zu verstehen
8. Ich fand die Benutzung des Systems sehr umständlich
9. Ich fühlte mich sehr sicher bei der Benutzung des Systems
10. Ich gibt eine Menge zu lernen, bevor man mit diesem System umgehen kann.

1	2	3	4	5

1	2	3	4	5

1	2	3	4	5

1	2	3	4	5

Vp.-Nr./Datum:

## Fragebogen zur Nutzbarkeit und Verständlichkeit

Anmerkungen

-

Vp.-Nr./Datum:

## Abschlussbefragung<sup>2</sup>

1. Wenn Sie nun mal die Erfahrungen, die Sie mit dem System bei der Versuchsfahrt gesammelt haben, zusammennehmen, würden Sie:

a. Ihr jetziges Fahrzeug nachträglich mit diesem System ausrüsten lassen?

Ja: \_\_\_\_                      Nein: \_

b. beim Kauf eines Neufahrzeuges dieses System als Zusatzausstattung haben wollen?

Ja: \_\_\_\_                      Nein: \_

c. die Serienausstattung aller Neufahrzeuge mit diesem System für sinnvoll halten?

Ja: \_ \_                      Nein: \_

2.) Wenn a.) und/oder b.) mit „Ja“ beantwortet wurden: Was für eine Summe wären Sie

bereit, für dieses System zusätzlich zu investieren:

a. Nachträglicher Einbau: \_\_\_\_\_ €

---

<sup>2</sup> Vom Versuchsleiter auszufüllen

b. Zusatzausstattung: \_ €

3.) Wo besteht bei diesem System Ihrer Ansicht nach noch Verbesserungsbedarf?

.

4.) Fragen zur Person

Alter: \_      Geschlecht: \_\_ (m/w)      Schulabschluss: \_

Beruf: r      Führerschein seit: \_\_\_\_\_

Privat genutzter Pkw (Typ), seit:      Jährliche KM-Leistung: ca.